

5

Integrating the Healthcare Enterprise



10

**IHE Eye Care (EYECARE)
Technical Framework**

15

**Volume 2
(EYECARE TF-2)
Transactions**

20

**Revision 3.7 – Final Text
February 15, 2010**

25

30 **Contents**

	1.1	Overview of Technical Framework.....	4
	1.2	Overview of Eye Care Volume II.....	5
	1.3	Audience.....	5
35	1.4	Relationship to Standards.....	6
	1.5	Relationship to Real-world Architectures.....	6
	1.6	Comments.....	7
	1.7	Copyright Permission.....	7
	2	Conventions.....	8
40	2.1	The Generic IHE Transaction Model.....	8
	2.2	DICOM Usage Conventions.....	9
	2.3	Use of Coded Entities and Coding Schemes.....	11
	3	Framework Overview.....	12
	4	IHE Transactions.....	13
45	4.1	Query Modality Worklist [EYECARE-1].....	13
	4.1.1	Scope.....	13
	4.1.2	Use Case Roles.....	13
	4.1.3	Referenced Standards.....	14
	4.1.4	Interaction Diagram.....	14
50	4.1.5	Issuer of Patient ID.....	15
	4.1.6	Procedure Instructions Option.....	15
	4.2	Modality Images/Evidence Stored [EYECARE-2].....	16
	4.2.1	Scope.....	16
	4.2.2	Use Case Roles.....	16
55	4.2.3	Referenced Standards.....	16
	4.2.4	Interaction Diagram.....	17
	4.2.5	EYE CARE Image Option.....	18
	4.2.6	Encapsulated PDF Option for Evidence Documents.....	21
	4.2.7	EYECARE Measurements Option.....	22
60	4.2.8	Ophthalmic Photography Relative Image Position Coding Option.....	23
	4.2.9	Stereo Relationship option.....	24
	4.2.10	Contrast Start Time Reporting in OP Images.....	24
	4.2.11	Acquisition Modality Importer Actor Storage.....	25
	4.3	Retrieve Images and Measurements [EYECARE-3].....	26
65	4.3.1	Scope.....	26
	4.3.2	Use Case Roles.....	26
	4.3.3	Referenced Standards.....	27
	4.3.4	Interaction Diagram.....	27
	4.3.5	EYECARE Image Option.....	28
70	4.3.6	Ophthalmic Photography Relative Image Position Coding Option.....	28
	4.3.7	Stereo Relationship option.....	29
	4.4	Query Evidence Documents [EYECARE-4].....	29
	4.4.1	Scope.....	29
	4.4.2	Use Case Roles.....	29

75	4.4.3 Referenced Standards	30
	4.4.4 Interaction Diagram.....	30
	4.4.5 DICOM Encapsulated PDF Query Attributes	30
	4.5 Query Images, Measurements and Encapsulated Documents [EYECARE-5].....	31
	4.5.1 Scope	31
80	4.5.2 Use Case Roles	31
	4.5.3 Referenced Standards	31
	4.5.4 Interaction Diagram.....	32
	4.5.5 Support Issuer of Patient ID	32
	4.6 Modality Procedure Step Completed/Discontinued [EYECARE-6].....	33
85	4.6.1 Scope	33
	4.6.2 Use Case Roles	33
	4.6.3 Referenced Standards	34
	4.6.4 Interaction Diagram.....	34
	4.7 Displayable Report Storage [EYECARE-7]	37
90	4.7.1 Scope	37
	4.7.2 Use Case Roles	37
	4.7.3 Referenced Standards	38
	4.7.4 Interaction Diagram.....	38
	4.7.5 DICOM Encapsulated Document Standard Extended Attributes	39
95	4.8 Query Displayable Report [EYECARE-8].....	42
	4.8.1 Scope	42
	4.8.2 Use Case Roles	42
	4.8.3 Referenced Standards	43
	4.8.4 Interaction Diagram.....	43
100	4.9 Retrieve Displayable Reports [EYECARE-9].....	45
	4.9.1 Scope	45
	4.9.2 Use Case Roles	45
	4.9.3 Referenced Standards	45
	4.9.4 Interaction Diagram.....	46
105	4.10 Instructions for Performing a Procedure- Placer Order Management [EYECARE-10]	48
	4.10.1 Scope	48
	4.10.2 Use Case Roles	48
	4.10.3 Referenced Standards	48
	4.10.4 Interaction Diagrams	49
110	4.11 Instructions for Performing a Procedure- Filler Order Management [EYECARE-11]..	50
	4.11.1 Scope	51
	4.11.2 Use Case Roles	51
	4.11.3 Referenced Standards	51
	4.11.4 Interaction Diagrams	52
115		

1 Introduction

120 Integrating the Healthcare Enterprise (IHE) is an initiative designed to stimulate the integration of the
information systems that support modern health care institutions. Its fundamental objective is to
ensure that in the care of patients all required information for medical decisions is both correct and
available to health care professionals. The IHE initiative is both a process and a forum for
encouraging integration efforts. It defines a technical framework for the implementation of
125 established messaging standards to achieve specific clinical goals. It includes a rigorous testing
process for the implementation of this framework. And it organizes educational sessions and exhibits
at major meetings of medical professionals to demonstrate the benefits of this framework and
encourage its adoption by industry and users.

The approach employed in the IHE initiative is to support the use of existing standards, e.g. HL7,
ASTM, DICOM, ISO, IETF, OASIS and others as appropriate, rather than to define new standards.
130 IHE profiles further constrain configuration choices where necessary in these standards to ensure that
they can be used in their respective domains in an integrated manner between different actors. When
clarifications or extensions to existing standards are necessary, IHE refers recommendations to the
relevant standards bodies.

This initiative has numerous sponsors and supporting organizations in different medical specialty
135 domains and geographical regions. In North America the primary sponsors are the Healthcare
Information and Management Systems Society (HIMSS) and the Radiological Society of North
America (RSNA). IHE Canada has also been formed. IHE Europe (IHE-EUR) is supported by a large
coalition of organizations including the European Association of Radiology (EAR) and European
Congress of Radiologists (ECR), the Coordination Committee of the Radiological and
140 Electromedical Industries (COCIR), Deutsche Röntgengesellschaft (DRG), the EuroPACS
Association, Groupement pour la Modernisation du Système d'Information Hospitalier (GMSIH),
Société Française de Radiologie (SFR), Società Italiana di Radiologia Medica (SIRM), and the
European Institute for health Records (EuroRec). In Japan IHE-J is sponsored by the Ministry of
Economy, Trade, and Industry (METI); the Ministry of Health, Labor, and Welfare; and MEDIS-DC;
145 cooperating organizations include the Japan Industries Association of Radiological Systems (JIRA),
the Japan Association of Healthcare Information Systems Industry (JAHIS), Japan Radiological
Society (JRS), Japan Society of Radiological Technology (JSRT), and the Japan Association of
Medical Informatics (JAMI). Other organizations representing health care professionals are invited to
join in the expansion of the IHE process across disciplinary and geographic boundaries.

150 1.1 Overview of Technical Framework

This document, the IHE Eye Care Technical Framework (EYECARE TF), defines specific
implementations of established standards to achieve integration goals that promote appropriate
155 sharing of medical information to support optimal patient care. It is expanded annually, after a period
of public review, and maintained regularly through the identification and correction of errata. The
current version, Rev 3.7 for Final Text, specifies the IHE transactions defined and implemented as of
2009. The latest version of the document is always available via the Internet at
http://www.ihe.net/Technical_Framework or at www.aao.org.

160 The IHE Eye Care Technical Framework identifies a subset of the functional components of the health care enterprise, called IHE actors, and specifies their interactions in terms of a set of coordinated, standards-based transactions. It describes this body of transactions in progressively greater depth. The present volume (EYECARE TF-1) provides a high-level view of IHE functionality, showing the transactions organized into functional units called integration profiles that highlight their capacity to address specific Eye Care requirements.

165 Volume 2 of the Eye Care Technical Framework provides detailed technical descriptions of each IHE transaction used in the Eye Care Integration Profiles. These volumes are consistent and can be used in conjunction with the Integration Profiles of other IHE domains.

170 The other domains within the IHE initiative also produce Technical Frameworks within their respective areas that together form the IHE Technical Framework. For example, the following IHE Technical Framework(s) are some of those which are available:

- 175
- IHE Eye Care Technical Framework
 - IT Infrastructure Technical Framework
 - IHE Cardiology Technical Framework
 - IHE Laboratory Technical Framework
 - IHE Patient Care Coordination Technical Framework
- 180
- IHE Radiology Technical Framework

Where applicable, references are made to other technical frameworks. For the conventions on referencing other frameworks, see EYECARE TF-1: 1.6.4.

1.2 Overview of Eye Care Volume II

185 The remainder of Section 1 further describes the general nature, purpose and function of the Technical Framework. Section 2 presents the conventions used in this volume to define IHE transactions.

190 Section 3 provides an overview of the concepts of IHE actors and transactions used in IHE to define the functional components of a distributed health care environment.

Section 4 defines transactions EYECARE-1 to EYECARE-11 in detail, specifying the roles for each actor, the standards employed, the information exchanged.

1.3 Audience

- 195 The intended audience of this document is:
- IT departments of health care institutions
 - Technical staff of vendors planning to participate in the IHE initiative
 - Experts involved in standards development
 - Those interested in integrating health care information systems and workflows

200 **1.4 Relationship to Standards**

The IHE Technical Framework identifies functional components of a distributed health care environment (referred to as IHE actors), solely from the point of view of their interactions in the health care enterprise. At its current level of development, it defines a coordinated set of transactions based on ASTM, DICOM, HL7, IETF, ISO, OASIS and W3C standards. As the scope of the IHE initiative expands, transactions based on other standards may be included as required.

In some cases, IHE recommends selection of specific options supported by these standards; however, IHE does not introduce technical choices that contradict conformance to these standards. If errors in or extensions to existing standards are identified, IHE's policy is to report them to the appropriate standards bodies for resolution within their conformance and standards evolution strategy.

IHE is therefore an implementation framework, not a standard. Conformance claims for products must still be made in direct reference to specific standards. In addition, vendors who have implemented IHE integration capabilities in their products may publish IHE Integration Statements to communicate their products' capabilities. Vendors publishing IHE Integration Statements accept full responsibility for their content. By comparing the IHE Integration Statements from different products, a user familiar with the IHE concepts of actors and integration profiles can determine the level of integration between them. See EYECARE TF-1: Appendix C for the format of IHE Integration Statements.

220 **1.5 Relationship to Real-world Architectures**

The IHE actors and transactions described in the IHE Technical Framework are abstractions of the real-world health care information system environment. While some of the transactions are traditionally performed by specific product categories (e.g. Hospital Information System (HIS), Clinical Data Repository, Radiology Information Systems, Clinical Information Systems or Cardiology Information Systems), the IHE Technical Framework intentionally avoids associating functions or actors with such product categories. For each Actor, the IHE Technical Framework defines only those functions associated with integrating information systems. The IHE definition of an Actor should therefore not be taken as the complete definition of any product that might implement it, nor should the framework itself be taken to comprehensively describe the architecture of a health care information system.

The reason for defining actors and transactions is to provide a basis for defining the interactions among functional components of the health care information system environment. In situations where a single physical product implements multiple functions, only the interfaces between the product and external functions in the environment are considered to be significant by the IHE initiative. Therefore, the IHE initiative takes no position as to the relative merits of an integrated environment based on a single, all-encompassing information system versus one based on multiple systems that together achieve the same end. IHE demonstrations emphasize the integration of multiple vendors' systems based on the IHE Technical Framework.

1.6 Comments

- 240 The Academy welcomes comments on this document and the IHE initiative. They should be directed to the discussion server at <http://forums.rsna.org/> or to:
Flora Lum, M.D.
Policy Director, Quality of Care and Knowledge Base Development
American Academy of Ophthalmology
- 245 e-mail: flum@aao.org

1.7 Copyright Permission

- 250 Health Level Seven, Inc. has granted permission to the IHE to reproduce tables from the HL7 standard. The HL7 tables in this document are copyrighted by Health Level Seven, Inc. All rights reserved.

The National Electrical Manufacturers Association (NEMA) has granted permission to the IHE to incorporate portions of the DICOM standard.

Material drawn from these documents is credited where used.

2 Conventions

255 This document has adopted the following conventions for representing the framework concepts and specifying how the standards upon which the IHE Eye Care Technical Framework is based shall be applied.

2.1 The Generic IHE Transaction Model

260 Transaction descriptions are provided in section 4. In each transaction description, the actors, the roles they play, and the transactions between them are presented as use cases.

The generic IHE transaction description includes the following components:

- **Scope:** a brief description of the transaction.
- **Use case roles:** textual definitions of the actors and their roles, with a simple diagram relating them, e.g.:

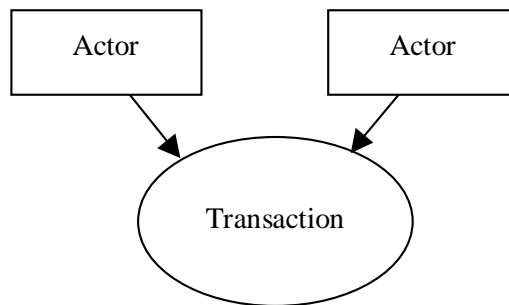

265

- *Referenced Standards:* the standards (stating the specific parts, chapters or sections thereof) to be used for the transaction.
- *Interaction Diagram:* a graphical depiction of the actors and transactions, with related processing within an actor shown as a rectangle and time progressing downward, similar to:

270

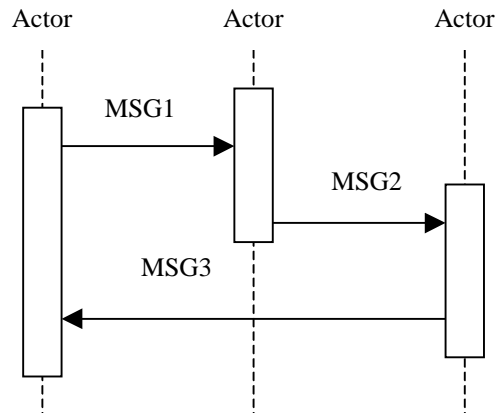

275 The interaction diagrams used in the IHE Technical Framework are modeled after those described in Grady Booch, James Rumbaugh, and Ivar Jacobson, *The Unified Modeling Language User Guide*, ISBN 0-201-57168-4. Simple acknowledgment messages are omitted from the diagrams for brevity. One or more messages may be required to satisfy a transaction. Each message is represented as an arrow starting from the Actor initiating the message.

- 280 • *Message definitions*: descriptions of each message involved in the transaction, the events that trigger the message, its semantics, and the actions that the message triggers in the receiver.

2.2 DICOM Usage Conventions

For some DICOM transactions described in this document, IHE has strengthened the requirements on the use of selected Type 2 and Type 3 attributes. These situations are explicitly documented in section 4 and in the appendices.

285 IHE specifically emphasizes that DICOM Type 2 attributes (for instance, Patient Name, Patient ID) shall be transmitted with zero length if the source system does not possess valid values for such attributes; in other words, the source system shall not assign default values to such attributes. The receiving system must be able to handle zero-length values for such attributes.

290 IHE has also defined requirements related to the support for and use of matching and return keys in DICOM queries by both Service Class Users (SCUs) and Service Class Providers (SCPs). Matching keys are used to select instances for inclusion in the response by the query SCP to the SCU, whereas return keys only return specific data and are not used for matching.

- Required matching key SCU:

295 A key that the Query SCU shall have the ability to offer to its user as a selection criterion. The definition of the means offered to the user of the Query SCU to trigger the sending of a matching key in the Query request is beyond the scope of IHE (e.g. enter a value, select an entry).

- Required matching key SCP:

An IHE required matching key is processed by the Query SCP just as if it were a DICOM-required matching key. In most cases, IHE-required matching keys are also DICOM-required matching keys.

- 300
- Required return key SCU:
A key that the Query SCU requests from the Query SCP, receives in the query responses, and displays for the user, if required. The definition of the means offered to the user of the Query SCU to request a return key (e.g. by default, check a box) and to make it visible to the user is beyond the scope of IHE.
 - Required return key SCP:
- 305 IHE-required return keys specified within DICOM as type 1 or type 2 return keys are processed according to their DICOM type. IHE-required return keys specified within DICOM as type 3 will be processed as if they were type 2.

Query Key Requirement Tables in the framework use the following legend to specify requirements for SCUs and SCPs:

- 310 R Required
O Optional

The following modifiers are also used:

- R+ The Requirement is an IHE extension of the DICOM requirements
315 R* The attribute is not required to be displayed

Table 2.2-1 provides an example table defining matching and return keys.

Table 2.2-1. Images Query Matching and Return Keys

Attributes Name	Tag	Query Keys Matching		Query Keys Return		Notes
		SCU	SCP	SCU	SCP	
Scheduled Human Performers Sequence	(0040,4034)	R+	R	R+*	R	
>Human Performer Code Sequence	(0040,4009)	R+	R	R+*	R	
>>Code Value	(0008,0100)	R+	R	R+*	R	
>>Coding Scheme Designator	(0008,0102)	R+	R	R+*	R	
>>Code Meaning	(0008,0104)	-	-	R+	R	Query Keys Matching SCU or SCP do not use the Code Meaning values ("-").
>Human Performer's Name	(0040,4037)	R+	R+	R+	R+	
>Human Performer's Organization	(0040,4036)	O	O	O	R+	
Referenced Study Component Sequence	(0008,1111)	O	O	O	O	

Attributes	Tag	Query Keys Matching		Query Keys Return		Notes
>Referenced SOP Class UID	(0008,1150)	O	O	O	R	
>Referenced SOP Instance UID	(0008,1155)	O	O	O	R	
Input Information Sequence	(0040,4021)	O	O	R+*	R	

320 **2.3 Use of Coded Entities and Coding Schemes**

IHE does not produce, maintain or otherwise specify a coding scheme or other resource for controlled terminology (coded entities). Where applicable, coding schemes required by the HL7 and DICOM standards take precedence. In the cases where such resources are not explicitly identified by the standards, implementations may utilize any resource (including proprietary or local) provided any licensing/copyright requirements are satisfied.

325

3 Framework Overview

The IHE Technical Framework is based on actors that interact through transactions.

Actors are information systems or components of information systems that produce, manage, or act on information associated with operational activities in the enterprise.

330 Transactions are interactions between actors that transfer the required information through standards-based messages.

Specific sets of actors and transactions are specified in the Integration Profiles (see EYECARE TF-1).

4 IHE Transactions

335 This section defines each IHE transaction in detail, specifying the standards used, the information transferred, and the conditions under which the transaction is required or optional.

4.1 Query Modality Worklist [EYECARE-1]

This transaction is identical to Query Modality Worklist [RAD-5] (see RAD TF-2: 4.5), with the addition of some features.

340

Note 1: The Radiology TF requires that the Acquisition Modality support at least one of the Worklist Query choices (i.e patient and/or Broad). Eye Care requires support for both options for both the Acquisition Modality and Acquisition Modality Importer. See EYECARE TF- 1:3.2.

345

Note 2: Request and Response portions of the Retrieve Document for Display transaction are not part of this profile and included for illustration purposes only.

4.1.1 Scope

This transaction takes place at the Acquisition Modality or the Acquisition Modality Importer (AMI) at the point of scan/acquisition. When a patient arrives for the scheduled procedure, the user performing the procedure must examine key information elements as they relate to the procedure, the correctness of the procedure that has been ordered, and comments that may have been entered by the referring health care provider. The user at the Acquisition Modality or the Acquisition Modality Importer uses the DICOM Modality Worklist to query the Department System Scheduler/Order Filler for Scheduled Procedure Steps. The list is downloaded to the modality and the user verifies the information on the modality console. In the Modality/Evidence Images Stored transaction this information will be included in the header of the generated objects (See RAD TF-2: 4.8 and RAD TF-2: Appendix A).

350

355

4.1.2 Use Case Roles

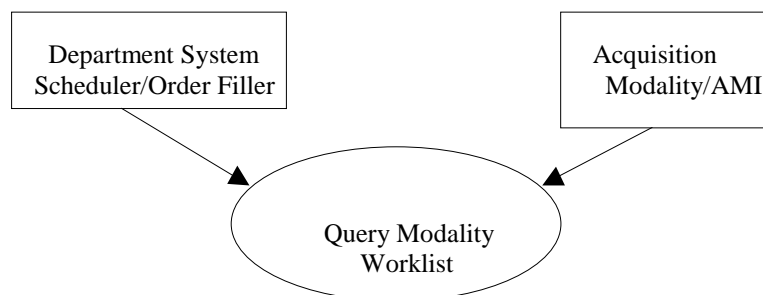

360 **Actor:** Acquisition Modality and Acquisition Modality Importer

Role: Responsible for requesting and receiving data from the Department System Scheduler/Order Filler, with the ability to validate the data and correct some discrepancies.

Actor: Department System Scheduler/Order Filler

365 **Role:** Responsible for accepting requests for MWL from an Acquisition Modality or Acquisition Modality Importer, performing the query, and sending the response back.

4.1.3 Referenced Standards

DICOM 2007 PS 3.4: Modality Worklist SOP Class

4.1.4 Interaction Diagram

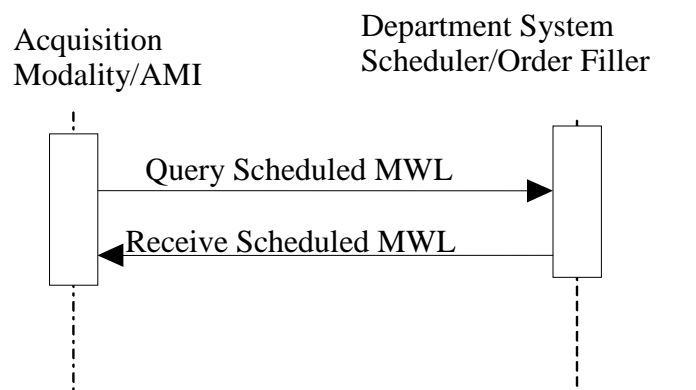

370 4.1.4.1 Query Scheduled MWL Message

This is the worklist query message sent to the Department System Scheduler/Order Filler.

4.1.4.1.1 Trigger Events

The patient arrives at the modality for a procedure.

4.1.4.1.2 Message Semantics

375 The Acquisition Modality or Acquisition Modality Importer uses the C-FIND Request of the DICOM Modality Worklist SOP Class to query for the worklist from the Department System Scheduler/Order Filler (DSS/Order Filler). The Acquisition Modality or Acquisition Modality Importer performs the SCU role, and the DSS/Order Filler performs the SCP role. The types of queries specified are defined in the RAD TF- 2: 4.5.

380 4.1.4.1.3 Expected Actions

The expected actions are defined in RAD TF-2: 4.5. This section provides some further explanation for one eye care use case.

385 Various types of acquisition devices are able to create ophthalmic photography images and/or ophthalmic tomography images. For example, both fundus cameras and slit-lamp biomicroscopes are able to create ophthalmic photography images. When performing Modality Worklist clinics may desire to schedule protocols for each device separately (i.e. see a separate list for the fundus and slit-lamp biomicroscopes). This use case is solved in most specialties by using the Modality attribute in the MWL query; however, since the modality for each device is

390 OP, this does not satisfy the use case in eye care. The solution to this use case is the DSS/OF managing the attribute Scheduled Station AE Title.

The Scheduled Station AE Title attribute is used to determine the actual device asking the MWL query. If the clinic wishes to schedule each device separately, then the Scheduled AE Title is used to distinguish between devices. However, this is not a very common case and more
 395 common is when a clinic wishes to schedule based upon device type. For this scenario, the DSS/OF provides the solution by creating a table of AE Titles for each type of similar device. Therefore, when the fundus camera and slit-lamp biomicroscope acquisition modalities use Scheduled Station AE Title in their MWL query, they will each receive a different list of scheduled procedures. This is just one scenario for how the DSS/OF should manage the attribute
 400 Scheduled Station AE Title. Others may also be required based upon the needs of the clinic.

4.1.5 Issuer of Patient ID

The ADT/Patient Registration actor transmits information regarding the assigning authority (issuer) of the Patient ID to the DSS/Order Filler Actor; this is defined in [RAD-1], see RAD TF-2: 4.1). However, [RAD-5] (see RAD TF-2: 4.5), does not required the DICOM attribute “Issuer
 405 of Patient ID” be filled in by the DSS/Order Filler actor if asked by the Acquisition Modality or Acquisition Modality Importer during a Modality Worklist query. This extension requires support for this attribute. See EYECARE TF-1: 3.3.1 for use case explanation.

For this EYECARE-1 extension, table 4.5-3 from [RAD-5], (see RAD TF-2: 4.5), shall be extended as defined by the following table entry.
 410

Table 4.1.5-1 Return and Matching Keys For Modality Worklist

Attribute Name	Tag	Query Keys Matching		Query Keys Return	
		SCU	SCP	SCU	SCP
Patient Identification					
Issuer of Patient ID	(0010,021)	O	O	O	R+

Note: The Acquisition Modality and Acquisition Modality Importer are not required to ask for the Issuer of Patient ID in their queries; however, if they do ask for the attribute, the DSS/Order Filler is required to return a valid value in the response.

415 **4.1.6 Procedure Instructions Option**

When an order for a procedure is created, a health care provider may wish to include instructions to the technician. For example there might be instructions to tape the eyelids while performing a visual field or to concentrate on a specific region of the eye during the early stage of an angiogram, etc.

420 This is accomplished when an Order Placer and/or DSS/Order Filler Actor transmits HL7 ORM messages which are defined in [EYECARE-10] and [EYECARE-11], see EYECARE TF-2: 4.10 and EYECARE TF-2: 4.11 for complete specifications.

If instructions for a procedure are provided, the DSS/OF shall convey these instructions to the Acquisition Modality or Acquisition Modality Importer during a Modality Worklist query using
 425 the DICOM attribute “Requested Procedure Comments”. The Acquisition Modality and/or

Acquisition Modality Importer Actors shall display the instructions to the technician prior to performing the procedure.

Table 4.1.6-1 Return and Matching Keys for Modality Worklist

Attribute Name	Tag	Query Keys Matching		Query Keys Return	
		SCU	SCP	SCU	SCP
Requested Procedure Comments					
Requested Procedure Comments	(0040,1400)	O	O	R+	R+

430 **4.2 Modality Images/Evidence Stored [EYECARE-2]**

This transaction is identical to Modality Images Stored [RAD-8] (see RAD TF-2: 4.8) except for the list of SOP Classes supported which are defined in later sections.

4.2.1 Scope

435 In the Modality Images/Evidence Stored transaction, the Acquisition Modality or Acquisition Modality Importer sends the acquired images/evidence documents to the Image Archive. The information provided from the Modality Worklist transaction (see RAD TF-2: 4.5) shall be included in the headers of the generated images.

4.2.2 Use Case Roles

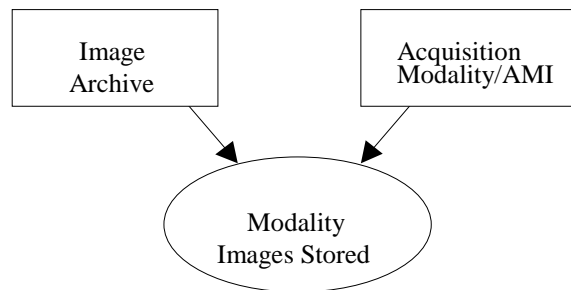

440 **Actor:** Acquisition Modality or Acquisition Modality Importer

Role: Transmit acquired image/evidence documents data to Image Archive.

Actor: Image Archive

Role: Accept and store images/evidence documents from Acquisition Modalities and Acquisition Modality Importers.

445 **4.2.3 Referenced Standards**

DICOM 2007 PS 3.4: Storage Service Class.

4.2.4 Interaction Diagram

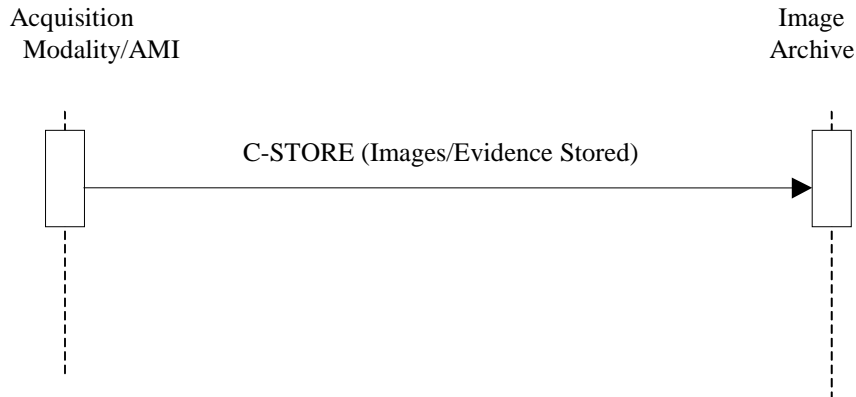

4.2.4.1 Images/Evidence Stored

450 4.2.4.1.1 Trigger Events

The Acquisition Modality or Acquisition Modality Importer can transfer images/evidence documents to the Image Archive sequentially within one or more DICOM associations, as the images/evidence documents become available or collectively.

4.2.4.1.1.1 Study UIDs and Series UIDs

455 Study UID creation details and timing are clearly defined by the IHE. The Radiology Scheduled Workflow and Patient Reconciliation Profiles explain how the Study information and identifiers such as the Study Instance UID are generated by the DSS/Order Filler and made available to the modality through the Modality Worklist. Generation of these items by the modality or workstation are restricted in general and are only permitted in specifically outlined exception cases, when a PPS is unscheduled (RAD TF-2: Appendix A, Table A.1-2) or when several SPS belonging to different Requested Procedures are satisfied by a single PPS (RAD TF-2: Appendix A, Table A.1-5).

Series UID creation must be compatible with a number of DICOM rules.

465 Multiple performed procedure steps are not permitted to reference the same series. So conversely, one series cannot contain the output of different performed procedure steps. Therefore, adding images/evidence documents to a series in a procedure step, which has been completed, is not permitted since a procedure step cannot be modified.

Note that a series *may* fulfill more than one *scheduled* procedure step.

470 Adding images/evidence documents after completion of a procedure step shall trigger the creation of a new series.

One series cannot contain the output of different equipment (in part because a series must have a single Frame Of Reference). Creating images/evidence documents on different equipment shall trigger the creation of a new series.

475 All images in a series must share the same Frame Of Reference. Generally this means creating images with different patient positioning shall trigger the creation of a new series. Note that if the Frame Of Reference is not present (at the Series level), this requirement is avoided.

Images/evidence documents reconstructed on a different piece of equipment are required to be in a separate Series.

480 For consistency, IHE specifies that derived and/or reconstructed images shall be stored in a separate series from the acquired images from which they were derived/reconstructed, regardless of whether they are derived/reconstructed on the Acquisition Modality, Acquisition Modality Importer or an Evidence Creator.

485 Note: Reconstructed and derived eye care image examples can include but are not limited to: mosaics, panoramas, 2-D/3-D renderings, superimposed images, combined images, statistical image maps, interpolated images, etc.

4.2.4.1.2 Message Semantics

490 The Acquisition Modality and Acquisition Modality Importers use the DICOM C-STORE message to transfer the images/evidence documents. The Acquisition Modality or Acquisition Modality Importer is the DICOM Storage SCU and the Image Archive is the DICOM Storage SCP.

495 The user validates the available information for the patient and the Scheduled Procedure Step/Requested Procedure. It is a requirement that certain information be recorded in the object header of the image/evidence document. The details of the mapping to DICOM image/evidence documents instances are specified in RAD TF-2: Appendix A. Effectively, this appendix strengthens the type definition of some DICOM attributes for the IHE Technical Framework

4.2.4.1.3 Issuer of Patient ID into Stored Images or Evidence Documents

500 EYECARE-1 defines the ability for Acquisition Modalities to query for the attribute Issuer of Patient ID using DICOM Modality Worklist, see section 4.1 for the specification. This section defines the requirement that this attribute be placed in the images and/or evidence documents if obtained via the query worklist.

If an Acquisition Modality or Acquisition Modality Importer actor obtains a valid value for the attribute Issuer Of Patient ID (0010,00210) via the Query Worklist Transaction, it shall include this attribute in any images and/or evidence documents it creates related to this specific patient.

4.2.5 Eye Care Image Option

505 Acquisition Modalities that support the Eye Care Image option shall support at least one of the SOP Classes defined by table 4.2.5-1.

Acquisition Modalities that support the Eye Care Image Option to create Ophthalmic Photography Images shall be able to support Ophthalmic 8 bit Photography and/or Ophthalmic 16 bit Photography Image Storage.

510 Acquisition Modalities that support the Eye Care Image Option to create Ophthalmic Tomography Images shall be able to support Ophthalmic Tomography Image Storage.

Image Archives that support the Eye Care Image Option shall support all of the SOP classes listed in Table 4.2.5-1.

515

Table 4.2.5-1 Eye Care Storage SOP Classes

SOP Class UID	SOP Class Name
1.2.840.10008.5.1.4.1.1.6.1	Ultrasound Image Storage
1.2.840.10008.5.1.4.1.1.3.1	Ultrasound Multi-frame Image Storage
1.2.840.10008.5.1.4.1.1.77.1.5.1	Ophthalmic 8 bit Photography Image Storage
1.2.840.10008.5.1.4.1.1.77.1.5.2	Ophthalmic 16 bit Photography Image Storage
1.2.840.10008.5.1.4.1.1.88.33	Stereometric Relationship Storage
1.2.840.10008.5.1.4.1.1.77.1.5.4	Ophthalmic Tomography Image Storage

Ophthalmic images may become very large as many are based upon multi-frame IODs. Thus image compression requirements are very important to ensure timely accessibility to such images. The compression specifications defined in this section are required for Acquisition Modalities that support the ophthalmic SOP Classes defined in table 4.2.5-2.

520

Table 4.2.5-2 Eye Care Image Storage SOP Classes

SOP Class UID	SOP Class Name
1.2.840.10008.5.1.4.1.1.6.1	Ultrasound Image Storage
1.2.840.10008.5.1.4.1.1.3.1	Ultrasound Multi-frame Image Storage
1.2.840.10008.5.1.4.1.1.77.1.5.1	Ophthalmic 8 bit Photography Image Storage
1.2.840.10008.5.1.4.1.1.77.1.5.2	Ophthalmic 16 bit Photography Image Storage
1.2.840.10008.5.1.4.1.1.77.1.5.4	Ophthalmic Tomography Image Storage

525 Transfer Syntaxes are identified and grouped into three categories: uncompressed, lossless compressed, and lossy compressed as per Table 4.2.5-3.

Table 4.2.5-3 Eye Care Standard Image Transfer Syntaxes

Category	SOP Class UID	SOP Class Name
Uncompressed	1.2.840.10008.1.2	Implicit VR Little Endian: Default Transfer Syntax for DICOM

Lossless Compressed	1.2.840.10008.1.2.4.70	JPEG Lossless, Non-Hierarchical, First-Order Prediction (Process 14 [Selection Value 1]): Default Transfer Syntax for Lossless JPEG Image Compression
	1.2.840.10008.1.2.4.90	JPEG 2000 Image Compression (Lossless Only)
Lossy Compressed	1.2.840.10008.1.2.4.50	JPEG Baseline (Process 1): Default Transfer Syntax for Lossy JPEG 8 Bit Image
	1.2.840.10008.1.2.4.91	JPEG 2000 Image Compression

530 Acquisition Modalities that support SOP classes specified in Table 4.2.5-2 shall be able to negotiate and offer at least one uncompressed, one lossless compressed and one lossy compressed transfer syntax from Table 4.2.5-3 (depending on the system configuration and/or user storage selection). However if the image acquisition chain of the Acquisition Modality is configured for lossy compression, the requirement for uncompressed or lossless compressed transfer syntaxes is waived; in this case only one of the lossy compressed transfer syntaxes from Table 4.2.5-3 is required. It is up to the Acquisition Modality to determine which transfer syntax of each category is most appropriate for the particular image(s) being stored.

540 IHE Eye Care does not currently address video applications (i.e. surgical microscopes, video ultrasound, etc.). Thus this specification does not specify DICOM Transfer Syntaxes such as MPEG2. However certain implementations may wish to use DICOM IODs such as the Ultrasound and OP for video solutions. Implementations that are using DICOM Eye Care IODs for video solutions only are not bound by the Transfer Syntax rules specified in this section.

Note: Future version of Eye Care may include specifications for video solutions.

545 Image Archives shall be able to negotiate, offer and accept any of the transfer syntaxes listed in Table 4.2.5-3.

Acquisition Modalities and Image Archives may support transfer syntaxes beyond what is specified in Table 4.2.5-3.

550 Note: Here are some practical examples of how to interpret these transfer syntax requirements:

- 1 - A digital fundus camera system may meet the requirements by allowing user configuration to store images using the DICOM default transfer syntax, JPEG lossless and JPEG lossy compression.
- 555 2 - A spectral domain OCT scanner which acquires images using up-front lossy compression may meet these requirements by supporting only JPEG 2000 compression.
- 3 - A digital surgical microscope system which acquires a video stream does not need to support the listed transfer syntaxes and may, for example, only support MPEG2.

4.2.5.1 Radiological Studies of the Eye

560 Healthcare providers frequently order radiological studies of the eye and surrounding anatomy. In many instances the interpretation of the study by a radiologist is all that is required. However, in certain instances such as suspected disease or trauma of the orbit (eye socket) or sinuses the ophthalmologist considers both a radiologist report and personal evaluation of the imaging study. One common example would be an orbital CT scan looking for fracture of the orbital floor, which may require surgical repair. Another example is the use of an orbital MRI looking for suspected tumor. Plain x-ray films of the facial bones may be obtained when there is trauma

near the eye. In all these instances the ophthalmologist gains specific diagnostic value by his or her own evaluation of the images and may also use this function in the OR to guide surgical intervention.

570 Image Display and Archive Actors are recommended to support the radiological SOP Classes defined in table 4.2.5.1-1.

Table 4.2.5.1-1. Radiological Studies SOP Classes

SOP Class UID	SOP Class Name
1.2.840.10008.5.1.4.1.1.1	Computed Radiography Image Storage
1.2.840.10008.5.1.4.1.1.1.1	Digital X-Ray Image Storage – For Presentation
1.2.840.10008.5.1.4.1.1.2	CT Image Storage
1.2.840.10008.5.1.4.1.1.4	MR Image Storage
1.2.840.10008.5.1.4.1.1.12.1	X-Ray Angiographic Image Storage
1.2.840.10008.5.1.4.1.1.7	Secondary Capture Image Storage

4.2.6 Encapsulated PDF Option for Evidence Documents

575 There are many Acquisition Modalities that create evidence documents in addition to or instead of standalone images such as derived images, combined data, measurements, plots, graphs and other diagnostic information.

Acquisition Modalities that support the Encapsulated PDF option shall support the SOP Class defined by table 4.2.6-1.

580 In 2008, DICOM SOP Classes have been defined for many devices that create measurements, such as lensometers, auto-refractors, keratometers, and subjective refraction devices. Therefore, they are required to support the Eye Care Measurements Option defined in section 4.2.8. Image Archives that support the Encapsulated PDF option shall support the SOP Class defined by table 4.2.6-1.

585 **Table 4.2.6-1. Eye Care SOP Classes for Evidence Documents**

SOP Class UID	SOP Class Name
1.2.840.10008.5.1.4.1.1.104.1	Encapsulated PDF Storage

4.2.6.1 Encapsulated PDF Option for Evidence Documents Attributes

4.2.6.1.1 Concept Name Code Sequence

590 The Concept Name Code Sequence is the attribute used to provide standardized coded titles for documents. Report Creators which support the Encapsulated PDF option should be able to configure this attribute based upon the clinic requirements or a chosen industry standard.

Note: This requirement allows users and implementations to identify the different types of encapsulated documents.

4.2.6.2 PDF Version Requirements

595 The DICOM standard does not define use of a specific version of PDF when encapsulated PDF is used. This may result in incorrect display of reports when using a different PDF version of software from that which was used to create the files. Common errors include blank or missing pages, missing or displaced graphics, or important changes in format, leading to risk for clinical error.

600 Another difficulty is that PDF files are very large when only pixel data is used in the file. This causes unacceptable clinical impacts such as very slow network transmission speeds. Pixel data PDFs also may cause unreadable display upon zooming in or out, allowing only small portions of a document to be viewed at one time, etc. When searchable PDF is used to store information as text the files are much smaller, solving many of the issues identified. The ability to search the text files is an additional critical benefit, allowing a clinician to locate specific information quickly.

605 ISO PDF based standards have been developed in order to address these issues. Acquisition Modality and Evidence Creator Actors shall support PDF/A ISO 19005-1. Document management – Electronic document file format for long-term preservation- Part 1: Use of PDF (PDF/A).

610 The PDF contents of the DICOM Encapsulated PDF objects shall conform to PDF/A-1a (level A conformance to the PDF/A Part 1 standard). This is intended to ensure that the rendered visual appearance of the document is reproducible across computer platforms and over the course of time, and that the document can be displayed in natural reading order on a mobile device (for example a PDA) or other devices in accordance with Section 508 of the US Rehabilitation Act.

615 The Image Display Actor shall conform to the PDF/A reader requirements for the display of DICOM Encapsulated PDF documents that are conformant to the PDF/A standard. This is intended to ensure the correct visual rendering of these documents.

4.2.7 Eye Care Measurements Option

620 There are many Acquisition Modalities in eye care that create measurement information, such as lensometers, auto-refractors, keratometers, and subjective refraction devices. This option allows support for such devices.

Acquisition Modalities that support the Eye Care Measurements option shall support at least one of the SOP Classes defined by table 4.2.7-1.

625 Image Archives that support the Eye Care Measurements Option are required to support all the SOP Classes defined in table 4.2.7-1.

Table 4.2.7-1. Eye Care Measurement Storage SOP Classes

SOP Class UID	SOP Class Name
1.2.840.10008.5.1.4.1.1.78.1	Lensometry Measurements
1.2.840.10008.5.1.4.1.1.78.2	Autorefractometry Measurements
1.2.840.10008.5.1.4.1.1.78.3	Keratometry Measurements

1.2.840.10008.5.1.4.1.1.78.4	Subjective Refraction Measurements
1.2.840.10008.5.1.4.1.1.78.5	Visual Acuity Measurements
1.2.840.10008.5.1.4.1.1.78.6	Spectacle Prescription Report

4.2.8 Ophthalmic Photography Relative Image Position Coding Option

630 When a health care provider is reading fundus photos it is occasionally difficult to determine what location in the retina, or even which eye, he or she is viewing. Laterality (right vs left eye) is a required attribute in DICOM Ophthalmic Photography Image SOP Classes, enabling image display vendors to display this information. However, the DICOM attribute Relative Image Position Code Sequence is an optional attribute and is often not conveyed in the OP images.

635 Acquisition Modality Actors that support the Relative Image Position Coding option shall support the requirements in tables 4.2.8-1 and 4.2.8-2.

Table 4.2.8-1. Relative Image Position Coding Extended Attributes and Codes

Attribute Name	Tag	Type
Relative Image Position Code Sequence	(0022,001D)	1C – Required for images that have an assigned imaging code review recommendation
>Include ‘Code Sequence Macro’ Table 8.8.1 Code Sequence Macro defined in DICOM 2007 PS 3.3: Information Object Definitions		Enumerated Value for Context ID 4207

640 The eye care domain may utilize many different image position codes. DICOM CID 4207 identifies some of these codes however health care providers may wish to utilize image position codes beyond CID 4207 according to other acquisition protocols. Acquisition Modality Actors shall support the extended codes defined in table 4.2.8-2 AND shall be configurable in order to support the codification scheme selected or defined by the health care enterprise.

645 4.2.8-2. Relative Image Position Extended Codes

Coding Scheme Designator (0008,0102)	Code Value (0008,0100)	Code Meaning (0008,0104)
99IHEEYECARE	330001	Macula centered
99IHEEYECARE	330002	Disc centered
99IHEEYECARE	330003	Mid-peripheral, superior
99IHEEYECARE	330004	Mid-peripheral, superior temporal
99IHEEYECARE	330005	Mid-peripheral, temporal
99IHEEYECARE	330006	Mid-peripheral, inferior temporal
99IHEEYECARE	330007	Mid-peripheral, inferior
99IHEEYECARE	330008	Mid-peripheral, inferior nasal

Coding Scheme Designator (0008,0102)	Code Value (0008,0100)	Code Meaning (0008,0104)
99IHEEYECARE	330009	Mid-peripheral, nasal
99IHEEYECARE	330010	Mid-peripheral, superior nasal
99IHEEYECARE	330011	Peripheral, superior
99IHEEYECARE	330012	Peripheral, superior temporal
99IHEEYECARE	330013	Peripheral, temporal
99IHEEYECARE	330014	Peripheral, inferior temporal
99IHEEYECARE	330015	Peripheral, inferior
99IHEEYECARE	330016	Peripheral, inferior nasal
99IHEEYECARE	330017	Peripheral, nasal
99IHEEYECARE	330018	Peripheral, superior nasal
99IHEEYECARE	330019	Lesion centered

4.2.9 Stereo Relationship option

650 Stereo photography such as for the optic disk requires determination of the stereo relationships between two OP images. The DICOM standard provides a mechanism for storing separate stereo relationship objects referencing the left and right images.

Acquisition Modality, Image Archive and Image Display actors supporting the Stereo Relationship option shall support the DICOM SOP Class defined in Table 4.2.9-1.

655 For the Acquisition Modality actor, this may involve user inputs to determine the left and right images, and possibly the horizontal displacement, vertical displacement and rotation of the right image relative to the left for optimal display. The Acquisition Modality actor may of course store the stereo relationships automatically without user input. If the device is aware of the angle of separation, the DICOM attribute Stereo Baseline Angle (0022,0010) should be conveyed.

660 The Acquisition Modality actor shall at minimum support determination of stereo relationships between single-frame images or individual frames of multi-frame images; it may support determination of stereo relationships between multiple frames of multi-frame images.

Table 4.2.9-1. Stereo Relationship SOP Class

SOP Class UID	SOP Class Name
1.2.840.10008.5.1.4.1.1.77.1.5.3	Stereometric Relationship Storage

4.2.10 Contrast Start Time Reporting in OP Images

665 The time stamp for initiation of contrast injection is termed Contrast Bolus start time. Timing of contrast injection is very important in some clinical settings, but due to variable clinical workflow in ophthalmic angiography there is potential for this data field to not strictly represent

670 the contrast injection time. The only way to control quality of this data is through proper
 implementation of the OP acquisition modality. This hinges on proper manufacturers’
 documentation, end user training, and strict attention to protocol during operation. Clinical
 settings where this feature may be useful include a variety of cerebral and ocular vascular
 occlusive diseases such as carotid artery occlusion, and central retinal artery/vein occlusion. As
 675 an example, in carotid occlusive disease a significant delay in the arm to retinal circulation time
 (ARCT) could be used to facilitate risk stratification for further cerebrovascular and
 cardiovascular work-up.

Table 4.2.10-1 Storage SOP Classes Requiring Contrast Tracking

SOP Class UID	SOP Class Name
1.2.840.10008.5.1.4.1.1.77.1.5.1	Ophthalmic 8 bit Photography Image Storage
1.2.840.10008.5.1.4.1.1.77.1.5.2	Ophthalmic 16 bit Photography Image Storage

680 Acquisition Modality Actors that support the SOP Classes specified in Table 4.2.10-1 shall
 support the attribute requirements as specified in Table 4.2.10-2 when contrast has been
 administered to the patient.

Table 4.2.10-2 Contrast Attribute Requirements

Attribute Name	Tag	Type	Attribute Description
>Contrast Administration Profile Sequence	(0018,9340)	1	Sequence that describes one or more phases of contrast administered. If present, shall contain one or more Items.
>>Contrast/Bolus Volume	(0018,1041)	2	Volume administered during this phase in milliliters of diluted contrast agent.
>>Contrast/Bolus Start Time	(0018,1042)	1	Time of start of administration.
>>Contrast/Bolus Stop Time	(0018,1043)	3	Time of end of administration.
>>Contrast Flow Rate	(0018,1046)	3	Rate of administration in milliliters/sec. Only a single value shall be present.
>>Contrast Flow Duration	(0018,1047)	3	Duration of injection in seconds. Only a single value shall be present.

4.2.11 Acquisition Modality Importer Actor Storage

685 Acquisition Modality Importer Actors provide IHE integration capabilities to eye care
 acquisition instruments that are not DICOM compatible. The storage requirements are very
 similar to Acquisition Modalities; however it may not be possible to obtain the acquisition
 modality’s internal data and may be necessary to interface via frame grabbers, printer ports and
 other mechanisms (this is not defined in IHE). Thus, they may also support DICOM SOP
 690 Classes that “capture” data from other devices.

Acquisition Modality Importer Actors shall support at least one of the SOP Classes defined in
 Tables 4.2.5-1 and/or 4.2.7-1 and/or 4.2.11-1.

Table 4.2.11-1. Acquisition Modality Importer Actor Capture SOP Classes

SOP Class UID	SOP Class Name
1.2.840.10008.5.1.4.1.1.104.1	Encapsulated PDF Storage
1.2.840.10008.5.1.4.1.1.7	Secondary Capture Image Storage
1.2.840.10008.5.1.4.1.1.7.2	Multi-frame Grayscale Byte Secondary Capture Image Storage
1.2.840.10008.5.1.4.1.1.7.3	Multi-frame Grayscale Word Secondary Capture Image Storage
1.2.840.10008.5.1.4.1.1.7.4	Multi-frame True Color Secondary Capture Image Storage

695

Eye Care modalities typically create three types of storage objects: image, measurement, and/or report-based.

700

- IHE recommends that the Acquisition Modality Importer Actor support a SOP Class from Table 4.2.5-1 for image-based objects and Table 4.2.7-1 for measurement-based objects.
- When this is not feasible, IHE recommends supporting one of the Secondary Capture Image Storage SOP Classes (see Table 4.2.11-1) for image-based objects and the Encapsulated PDF Storage SOP Class for measurement/report/text-based objects. When supporting Encapsulated PDF, it is highly recommended that the format of the document is PDF/A.

705

4.3 Retrieve Images and Measurements [EYECARE-3]

This transaction is identical to Retrieve Images [RAD-16] (see RAD TF-2: 4.16), with the addition of also retrieving refractive measurements.

710

4.3.1 Scope

After the Image Display request for retrieval, the requested DICOM Images and/or measurements are transferred from the Image Archive to the Image Display for viewing.

4.3.2 Use Case Roles

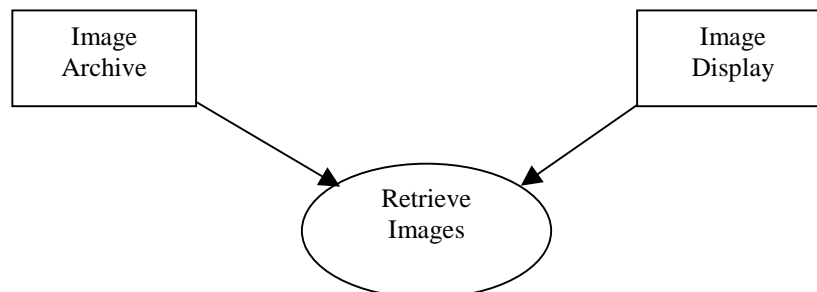

715

Actor: Image Archive:

Role: Sends requested images to the Image Display Actor.

Actor: Image Display

Role: Receives requested images from the Image Archive Actor.

4.3.3 Referenced Standards

720 DICOM 2007 PS 3.4: Storage Service Class

DICOM 2007 PS 3.4: Query/Retrieve Service Class

4.3.4 Interaction Diagram

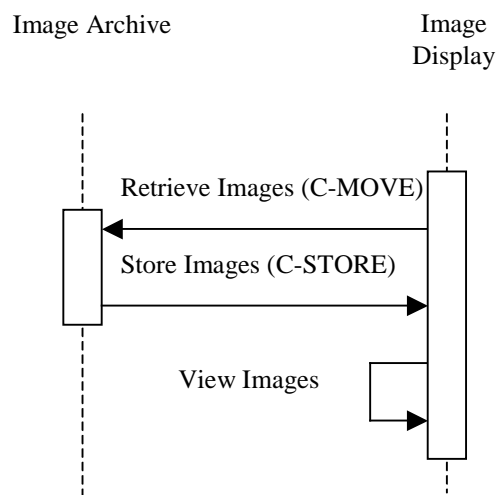

4.3.4.1 Retrieve Images

725 The Retrieve (Study Root – MOVE and optionally Patient Root – MOVE) SOP Classes shall be supported. The DICOM Image Storage SOP Classes will be supported by the Image Archive as an SCU. Refer to DICOM 2007 PS 3.4, Annex C, for detailed descriptive semantics.

4.3.4.1.1 Trigger Events

Images and/or measurements are selected for viewing at the Image Display.

730 4.3.4.1.2 Message Semantics

The message semantics are defined by the DICOM Query/Retrieve SOP Classes and the DICOM Image and Measurements Storage SOP Classes.

735 A C-MOVE Request from the DICOM Study Root Query/Retrieve Information Model – MOVE SOP Class or the DICOM Patient Root Query/Retrieve Information Model – MOVE SOP Class shall be sent from the Image Display to the Image Archive.

4.3.4.1.3 Expected Actions

740 The Image Archive receives the C-MOVE request, establishes a DICOM association with the Image Display and uses the C-STORE request (for the appropriate DICOM Image and/or Measurements Storage SOP Classes) to transfer the requested images. The Image Display is expected to support at least one of the SOP Classes specified in table 4.2.5-1 and/or 4.2.5-3 and/or 4.2.7-1. Support of retrieval for a SOP Class also means support for display.

4.3.5 EYECARE Image Option

745 Image Display actors that support the EYECARE Image Option shall support one or more of the SOP classes listed in Table 4.2.5-1 and/or 4.2.7-1. Other specialties, such as radiology, may obtain images of the eye. Examples include CTs, MR, X-Rays, etc. IHE Eye Care does not list these possibilities but recommends that Image Display actors be able to display such images. All Storage SOP classes supported by Image Display actors shall be documented in the DICOM conformance statement.

750 Note: A few examples are X-rays of an eye for foreign body, X-ray angiography to assess vascular orbital lesions, CT or MR of orbits, etc.

Image Display actors that support the EYECARE Image Option shall be able to negotiate, offer and accept the transfer syntaxes defined in Table 4.2.5-3 when supporting SOP Classes in Table 4.2.5-2.

755 When the Image Display Actor supports retrieval of DICOM Encapsulated PDF SOP Classes it shall support PDF/A ISO 19005-1. Document management – Electronic document file format for long-term preservation- Part 1: Use of PDF (PDF/A).

760 The Image Display Actor shall conform to the PDF/A reader requirements for the display of DICOM Encapsulated PDF documents that are conformant to the PDF/A standard. This is intended to ensure the correct visual rendering of these documents.

4.3.6 Ophthalmic Photography Relative Image Position Coding Option

765 When a health care provider is reading fundus photos it is occasionally difficult to determine what location in the retina, or even which eye, he or she is viewing. Laterality (right vs left eye) is a required attribute in DICOM Ophthalmic Photography Image SOP Classes, enabling image display vendors to display this information. However, the DICOM attribute Relative Image Position Code Sequence is an optional attribute and is often not conveyed in the OP images.

Image Display Actors that support the Relative Image Position Coding option shall support the requirements in Tables 4.2.8-1 and 4.2.8-2.

770 Image Display actors conforming to the Relative Image Position option shall support explicit and/or implicit display of DICOM Relative Image Position Code Sequence attributes (0022,001D) contained in OP images. For explicit display, the Image Display actor shall allow displaying the relative image position code meaning(s) for OP images (if any). For implicit display, the Image Display actor shall allow arranging the display layout of multiple images as a

775 function of their relative image position codes in such a manner as to unambiguously communicate their relative image position to the user.

4.3.7 Stereo Relationship option

Stereo photography such as for the optic disk requires determination of the stereo relationships between two OP images. The DICOM standard provides a mechanism for storing separate stereo relationship objects referencing the left and right images.

780 Image Archive and Image Display actors supporting the Stereo Relationship option shall support the DICOM SOP Class defined in Table 4.2.9-1.

785 An Image Display actor supporting the Stereo Relationship option shall support the SOP Class defined in table display of image pairs referenced by DICOM stereo relationship objects. The display of the right image relative to the left shall reflect any horizontal displacement, vertical displacement, and/or rotation of the right image relative to the left for optimal display.

The Image Display actor conforming to this option shall support display of stereo relationships defined for single-frame images, individual frames of multi-frame images, or multiple frames of multi-frame images. The display of multiple pairs of stereo frames may be restricted to display of one stereo pair at a time.

790 4.4 Query Evidence Documents [EYECARE-4]

This transaction is identical to Query Evidence Documents [RAD-44] (see RAD TF-3: 4.44), with the addition of querying for DICOM Encapsulated PDF document.

4.4.1 Scope

795 This section describes the sequence of Transactions required for the Image Display to query the Image Archive for instances of Evidence Documents.

4.4.2 Use Case Roles

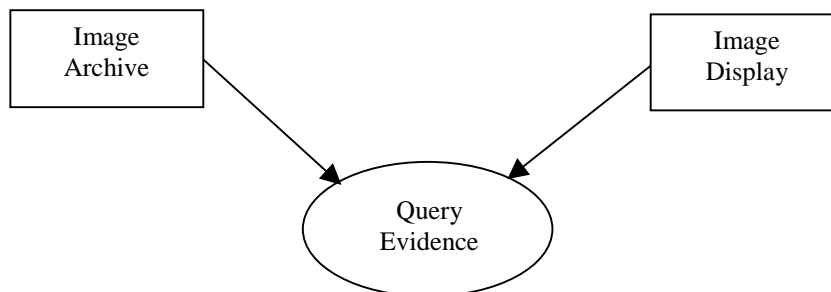

Actor: Image Display

Role: Query for Evidence Documents objects (generally in order to retrieve them).

800 **Actor:** Image Archive

Role: Respond to queries from the Image Display for Evidence Documents objects.

4.4.3 Referenced Standards

DICOM 2007 PS 3.4: Query/Retrieve Service Class

4.4.4 Interaction Diagram

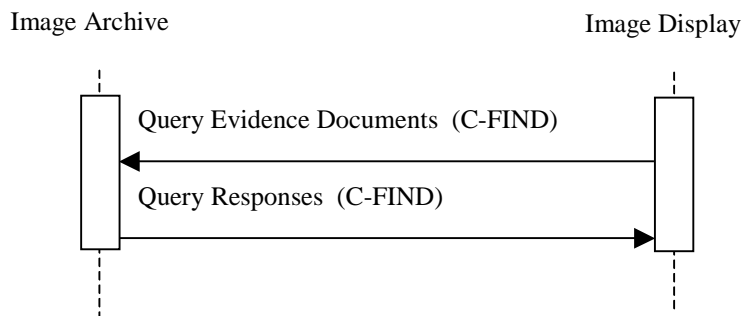

805

4.4.4.1 Query Evidence Documents

The Query (Study Root – FIND and optionally Patient Root – FIND) SOP Classes shall be supported. Refer to DICOM 2007 PS 3.4: Query/Retrieve Service Class for detailed descriptive semantics.

810 4.4.4.1.1 Trigger Events

Image Display needs to obtain information about Evidence Documents.

4.4.4.1.2 Message Semantics

The message semantics are defined by the DICOM Query/Retrieve SOP Classes.

815 A C-FIND Request from the DICOM Study Root Query/Retrieve Information Model – FIND SOP Class or the DICOM Patient Root Query/Retrieve Information Model – FIND SOP Class shall be sent from the Image Display to the Image Archive.

The Image Display uses one or more matching keys as filter criteria to obtain the list of matching entries in the Image Archive at the selected level (Patient & Study/Series/Instance).

820 In addition to the required and unique keys defined by the DICOM Standard, the IHE Technical Framework has defined matching and return keys to be supported by query SCUs and SCPs. The keys are defined in section RAD TF-2: 4.14.4.1.2 and table RAD TF-2: 4.14-1. The conventions for key usage are defined in RAD TF-2: 2.2. For the Image Display (SCU) and the Image Archive (SCP) the additional Evidence Document Instances specific keys are defined in table RAD TF-3: 4.44-1.

825 4.4.5 DICOM Encapsulated PDF Query Attributes

RAD-44 defines the ability for Evidence Creators (and other actors) to query Image Archives for evidence document information. This transaction is a simple extension to RAD-44 as it adds the support for DICOM Encapsulated PDF query attribute to display the Document Title.

830 Evidence Creators and Image Archives shall support the transaction as defined by RAD-44 with the addition of the requirements defined in table 4.4.5-1.

Table 4.4.5-1. Additional Query Matching and Return Keys for DICOM Encapsulated PDF Support

Attribute Name	Tag	Query Keys Matching		Query Keys Return	
		SCU	SCP	SCU	SCP
Encapsulated Document Instance Specific Level					
Document Title	(0042,0010)	O	O	R+	R+

835 Note: A workstation and/or acquisition modality supporting the Eye Care Evidence Document profile may perform a single query to obtain information about both images and evidence documents (i.e. two queries are not required). Similarly, when retrieving the information one retrieve could be used to obtain both images and evidence documents.

840 4.5 Query Images, Measurements and Encapsulated Documents [EYECARE-5]

This transaction is identical to Query Images [RAD-14] (see RAD TF- 2: 4.14), with the additional requirement that the Image Archive support the attribute Issuer of Patient ID.

4.5.1 Scope

The Image Display queries the Image Archive for study, series and image instances for retrieval.

845 4.5.2 Use Case Roles

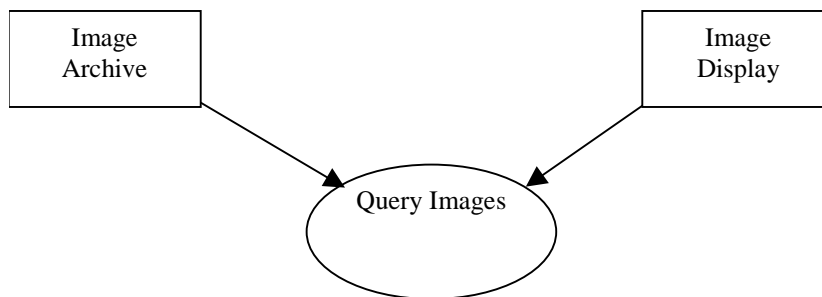

Actor: Image Archive

Role: Responds to queries for Studies, Series, and Images.

Actor: Image Display

850 **Role:** Issues Queries for Studies, Series, Images

4.5.3 Referenced Standards

DICOM 2007 PS 3.4: Query/Retrieve Service Class

4.5.4 Interaction Diagram

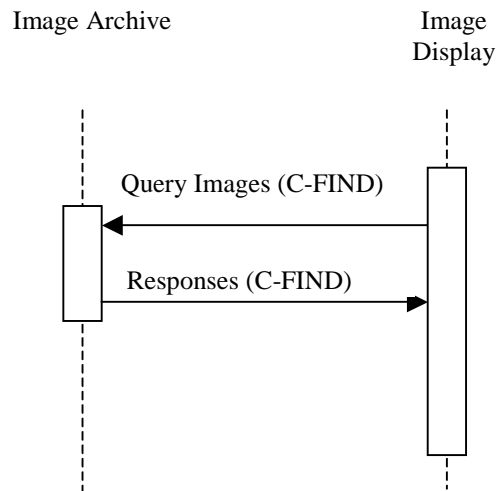

855 4.5.4.1 Query Images, Measurements and Encapsulated Documents

The Query (Study Root – FIND and optionally Patient Root – FIND) SOP Classes shall be supported. Refer to DICOM 2007 PS 3.4 for detailed descriptive semantics.

4.5.4.1.1 Trigger Events

The user at the Image Display wishes to view selected images.

860 4.5.4.1.2 Message Semantics

The message semantics are defined by the DICOM Query/Retrieve SOP Classes.

A C-FIND Request from the DICOM Study Root Query/Retrieve Information Model – FIND SOP Class or optionally the DICOM Patient Root Query/Retrieve Information Model – FIND SOP Class shall be sent from the Image Display to the Image Archive. Hierarchical Search Method shall be supported.

865

The Image Display uses one or more matching keys as search criteria to obtain the list of matching entries in the Image Archive at the selected level (Patient & Study/Series/Image). Based on this list of entries, the Image Display may select relevant entries to be retrieved.

870 The matching keys and return keys to be supported by the Image Display (SCU) and the Image Manager (SCP) are defined in the table defined in [RAD-14] (see RAD TF-2: 4.14), . The table specifies for both the Query SCU (Image Display) and the Query SCP (Image Archive) if Matching Keys (keys used as matching criteria in the Query request) and Returned Keys (Keys used to request attributes to be returned in the query responses) are Required (R) or Optional (O).

4.5.5 Support Issuer of Patient ID

875 RAD-14 defines the ability for Image Display actors to query Image Archives for images. This transaction is a simple extension to RAD-14 as it adds the support for the attribute Issuer of Patient ID.

Image Display and Image Archives shall support the transaction as defined by RAD-14 with the addition of the requirements defined in table 4.5.5-1.

880

Table 4.5-1. Images Query Matching and Return Keys

Attributes Name	Tag	Query Keys Matching		Query Keys Return		Notes
		SCU	SCP	SCU	SCP	
Study Level						
Issuer Of Patient ID	(0010,0020)	O	O	O	R+	See Note 1

Note: The Image Display is not required to ask for the Issuer of Patient ID in its query; however, if it does ask for the attribute, the Image Archive is required to return a valid value in the response (if it exists).

885

4.6 Modality Procedure Step Completed/Discontinued [EYECARE-6]

This transaction is identical to Modality Procedure Step Completed [RAD-7] (see RAD TF- 2: 4.7); with the additional requirement that that Acquisition Modalities or Acquisition Modality Importers convey the attribute Performed Protocol Code Sequence in the MPPS message. The Department System Scheduler/Order Filler, Image Manager, Performed Procedure Step Manager, Acquisition Modality, and Acquisition Modality Importer actors use transaction EYECARE-6.

890

4.6.1 Scope

This transaction includes a message from the Acquisition Modality or Acquisition Modality Importer to the Performed Procedure Step Manager, which in turn issues messages to the DSS/Order Filler and the Image Manager that the Performed Procedure Step has been completed. Information is not being released for billing at this point but a code may be assigned. The Image Manager may need the information to co-locate images of the same study. The Modality Procedure Step Completed message does not necessarily mean that the set of images is complete or available for retrieval.

900

4.6.2 Use Case Roles

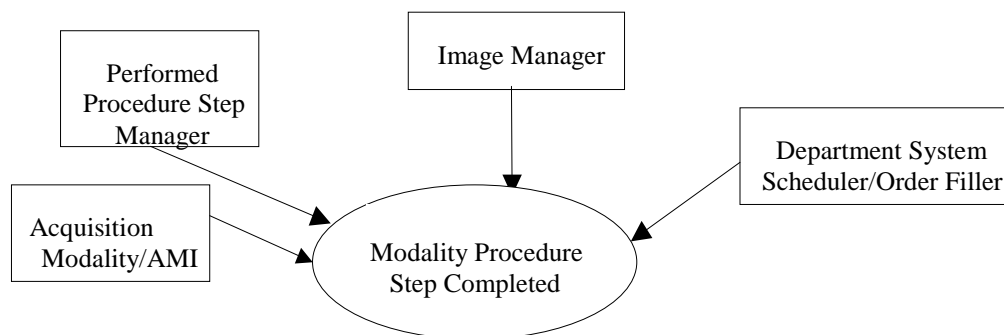

Actor: Department System Scheduler/Order Filler.

905 **Role:** Receives the PPS information forwarded by the PPS Manager.

Actor: Image Manager.

Role: Receives the PPS information forwarded by the PPS Manager.

Actor: Acquisition Modality or Acquisition Modality Importer.

910 **Role:** Informs the Performed Procedure Step Manager that a particular Performed Procedure Step is completed.

Actor: Performed Procedure Step Manager.

Role: Accepts Performed Procedure Step information from an Acquisition Modality or Acquisition Modality Importer and transmits it to the Department System Scheduler/Order Filler and Image Manager.

915 4.6.3 Referenced Standards

DICOM 2007 PS 3.4: Modality Performed Procedure Step SOP Class.

DICOM 2007 PS 3.16: DCMR Context Groups (Normative)

4.6.4 Interaction Diagram

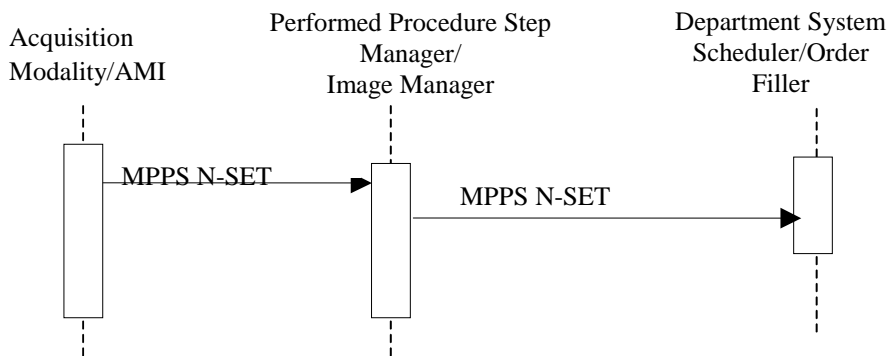

920

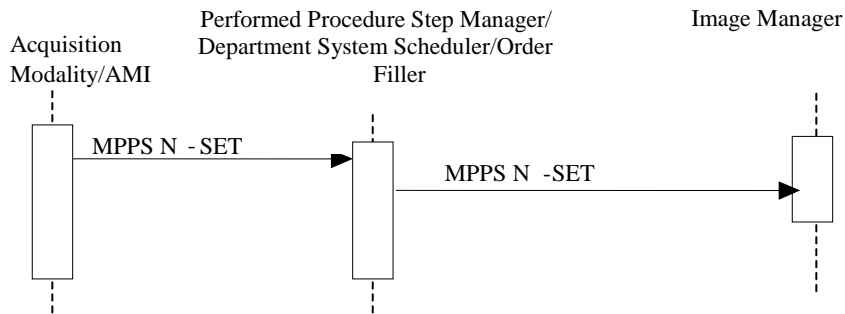

925 Note: The diagram above shows the sequencing of messages for the Modality Performed Procedure Step SOP Class. Acquisition Modalities and Acquisition Modality Importers will also implement the Storage and Storage Commitment classes. The timing relationship between PPS messages and Storage and Storage Commitment messages is not specified. That is, PPS messages may occur before or after storage requests.

4.6.4.1 Modality Procedure Step Completed/Discontinued [EYECARE-6]

930 RAD-7 defines the requirements and options for supporting Modality Procedure Step Completed/Discontinued. This transaction is a simple extension to RAD-7 as it adds the additional requirement that Acquisition Modalities and Acquisition Modality Importers convey the attribute Performed Protocol Code Sequence in the MPPS message.

935 Department System Scheduler/Order Filler, Image Manager, Performed Procedure Step Manager, Acquisition Modality, and Acquisition Modality Importer actors are required to support RAD-7 as defined in RAD TF-2: 4.7 with the following extensions.

4.6.4.2 Performed Protocol Code Sequence

A Modality Protocol Table shall be configured on the Acquisition Modality and Acquisition Modality Importer Actor. This table shall be synchronized with the Image Manager and the Department System Scheduler/Order Filler Actors.

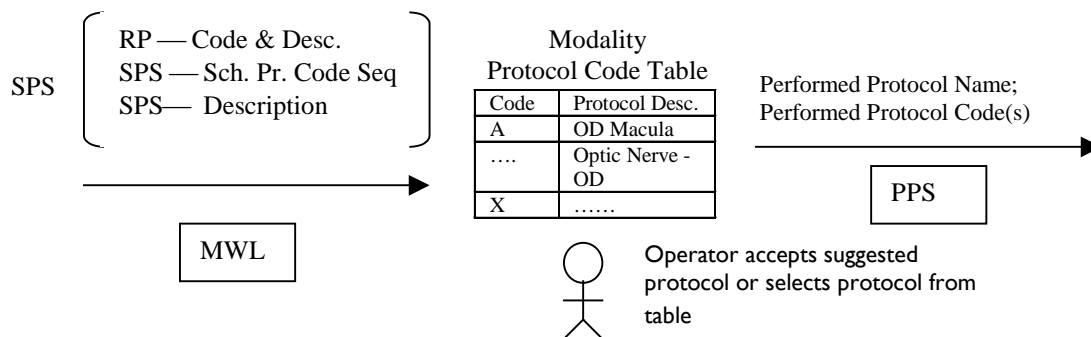

Upon obtaining a MWL from the Department System Scheduler/Order Filler the Acquisition Modality or Acquisition Modality Importer is required to display the attributes Scheduled Protocol Code Sequence and Scheduled Procedure Step Description (this requirement is part of RAD-5 and [EYECARE-1]).

- 945 For this requirement, the modality operator shall either accept/select the protocol, proposed in attribute Scheduled Protocol Code Sequence, or select an alternative protocol defined in the list of possibilities from Modality Protocol Table. The operator shall not manually enter the attributes (i.e. type in the protocol code) of the acquisition protocol but use the list from the Modality Protocol Table. This simplifies the operator's work on the modality and enables a better management of the protocols used in an imaging department. The Acquisition Modality or Acquisition Modality Importer actor shall provide the selected protocol code value in the attribute Performed Protocol Code Sequence in addition to the Protocol Name. This feature facilitates the role of the Department System Scheduler/Order Filler within the Charge Posting Integration Profile.
- 950
- 955 This feature does not define a specific codification of acquisition protocols. The involved actors, Department System Scheduler, Acquisition Modality, Acquisition Modality Importer and Image Manager/Archive shall be configurable in order to support the codification scheme selected or defined by the health care enterprise.

4.6.4.3 Trigger Event

- 960 Operator completes procedure step from the modality console.

4.6.4.4 Message Semantics

- The Acquisition Modality or Acquisition Modality Importer uses the Modality Performed Procedure Step SOP Class (N-SET service) to inform the Performed Procedure Step Manager that a specific Performed Procedure Step has been completed or discontinued. The Acquisition Modality or Acquisition Modality Importer may use the MPPS N-SET service to send intermediate updates of the Performed Procedure Step information.
- 965

The final N-SET has either the MPPS status of "COMPLETED" or "DISCONTINUED". The Performed Procedure Step Manager sends corresponding N-SETs to the Department System Scheduler/Order Filler and Image Manager.

- 970 When an N-SET is issued with a "DISCONTINUED" status, one or more Series of Instances may be referenced, if images were created and sent. Those Instances shall be Stored and Storage Committed

- Along with other information, the Acquisition Modality or Acquisition Modality Importer shall transmit information about the protocol it used to produce the SOP instances to the recipients.
- 975 See Protocol Handling in section RAD TF-2: 4.6.4.1.2.4 for detailed discussion of this issue.

Note 1: DICOM specifies that when attributes are allowed to be set by an N-SET, the value provided by the last N-SET overrides any value set by an earlier N-CREATE or N-SET.

- 980 Note 2: It is difficult for implementations of an Acquisition Modality Importer Actor to manage the transition from starting an MPPS (i.e., MPPS N-CREATE with a status of IN_PROGRESS) to finishing an MPPS (i.e. MPPS N-SET with a status of

985 COMPLETED or DISCONTINUED). This is because these Acquisition Modality Importer Actors often cannot know exactly when the modality starts and ends the procedure. Actually, it may be typical to know only when the procedure is finished. The DICOM MPPS workflow requires the N-CREATE/N-SET commands be transmitted, thus the Acquisition Modality Importer Actor is required to send both DICOM commands even though it may only know when the procedure step was finished. Implementations receiving these DICOM commands should be aware that the MPPS start and end times may not be accurate.

4.6.4.4.1 Expected Actions

990 The Image Manager and Department System Scheduler/Order Filler receive information about the Performed Procedure Step being complete or discontinued and link it with the Requested Procedure and Scheduled Procedure Step. The Image Manager and Department System Scheduler are not required to act on intermediate N-SET messages with the MPPS Status "IN PROGRESS".

995 The Requested Procedure may be considered complete if all Performed Procedure Steps related to all Scheduled Procedure Steps have been completed (or properly discontinued). Additional new (unscheduled) Performed Steps may be performed at any time, even after the Requested Procedure has been assigned complete scanning status. See relationship between Scheduled and Performed Procedure Steps in sec. RAD TF-2: 4.6.4.1.2.3 for detailed discussion of this issue.

4.7 Displayable Report Storage [EYECARE-7]

1000 This section corresponds to Transaction EYECARE-7 of the IHE Technical Framework. Transaction EYECARE-7 is used by the Report Creator and Report Repository actors.

4.7.1 Scope

In the Report Storage transaction, the Report Creator transmits a DICOM Encapsulated Document object to the Report Repository.

1005 4.7.2 Use Case Roles

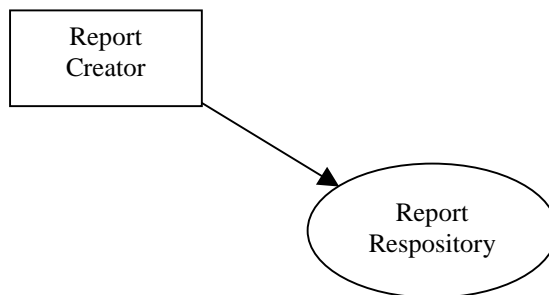

Actor: Report Creator

Role: Transmit draft or final DICOM Encapsulated document Reports to Report Repository.

Actor: Report Repository

1010 **Role:** Receive draft and final DICOM Encapsulated document Reports for storage

4.7.3 Referenced Standards

DICOM 2007 PS 3.4: Storage SOP Class

4.7.4 Interaction Diagram

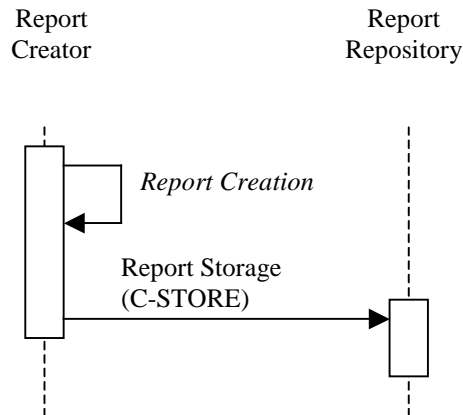

1015 4.7.4.1 Report Creation

This transaction relates to the “Report Creation” event in the above interaction diagram.

4.7.4.1.1 Trigger Events

The user at the Report Creator wishes to create a clinical report using DICOM Encapsulated Document.

1020 4.7.4.1.2 Invocation Semantics

This is a local invocation of functions at the Report Creator, and the method used by the Report Creator to obtain report data and create a DICOM Encapsulated document object is outside the scope of the IHE Technical Framework. The Report Creator shall create a report that conforms to the DICOM Encapsulated document defined in section 4.7.5.

1025 4.7.4.1.3 Expected Actions

Creation of DICOM Encapsulated document objects ready for storage to the Report Repository.

4.7.4.1.3.1 Study Identification and Identical Documents Sequence

1030 A Study Instance UID is required to identify the study to which the report belongs. It is recommended to use the Study Instance UID of the images and/or measurements reported on as the Study Instance UID of the created encapsulated document. If a Report Creator is generating a single report for multiple studies, it shall create multiple copies of the report, with different SOP Instance UIDs for each report and use the Identical Documents Sequence attribute (0040,A525) in each report. The Identical Documents Sequence attribute (0040,A525) in each report shall reference each of the other identical reports in the other studies. The actual content of the report
 1035 (except the Identical Documents Sequence attribute) shall be the same in each report instance.

The Retrieve AE Title attribute (0008,0054) in the Identical Documents Sequence Items shall not be sent.

4.7.4.2 Report Submission

1040 This transaction relates to the “DICOM C-STORE” event between the Report Creator and Report Repository in the above interaction diagram.

4.7.4.2.1 Trigger Events

When report authoring is completed and the Report Creator creates a new DICOM Encapsulated document the Report Creator shall transfer the DICOM Encapsulated document to the Report Repository.

1045 4.7.4.2.2 Message Semantics

The Report Creator uses the DICOM C-STORE message to transfer DICOM Encapsulated document reports. The DICOM Encapsulated document Instance shall include the additional attributes shown in Table 4.7.5-1. The Report Repository shall support Level 2 (Full) storage, which means all DICOM Type 1, 2 and 3 and private attributes are stored.

1050 4.7.4.2.3 Expected Actions

The Report Repository shall store the received DICOM Encapsulated document objects. At this point, the Report Creator relinquishes any responsibility for the report objects and may not change them in any way without creating a new object with a new SOP Instance UID. The Report Repository shall make the Instances available for query and retrieve.

1055

4.7.5 DICOM Encapsulated Document Standard Extended Attributes

The Report Creator and Report Repository shall support the DICOM SOP Classes defined in Table 4.7.5-1 and the Standard Extended Attributes defined in table 4.7.5-2.

1060

Table 4.7.5-1. SOP Classes for Encapsulated Documents

SOP Class UID	SOP Class Name
1.2.840.10008.5.1.4.1.1.104.1	Encapsulated PDF Storage

Table 4.7.5-2 DICOM Encapsulated Documents Standard Extended Attributes

Attribute Name	Tag	Type	Attribute Description
Verification Flag	(0040,A493)	1	Indicates whether this Document is Verified. Enumerated Values: UNVERIFIED = Not attested to. VERIFIED = Attested to by a Verifying Observer Name (0040,A075) who is accountable for its content.

IHE EYE CARE Technical Framework, vol. II: Transactions

Attribute Name	Tag	Type	Attribute Description
			<p>Note 1: The intent of this specification is that the "prevailing final version" of an Encapsulated Document is the version having the most recent Verification DateTime (0040,A030), Completion Flag (0040,A491) of COMPLETE and Verification Flag (0040,A493) of VERIFIED.</p> <p>Note 2: Eye care has made this attribute a Type 1 field, as it is only Type 3 in the Encapsulated IOD definition.</p>
Content Date	(0008,0023)	1	<p>The date the document content creation started.</p> <p>Note: Eye care has made this attribute a Type 1 field, as it is only Type 2 in the Encapsulated IOD definition.</p>
Content Time	(0008,0033)	1	<p>The time the document content creation started.</p> <p>Note: Eye care has made this attribute a Type 1 field, as it is only Type 2 in the Encapsulated IOD definition.</p>
Completion Flag	(0040,A491)	1	<p>The estimated degree of completeness of this Document with respect to externally defined criteria in a manner specified in the Conformance Statement.</p> <p>Note: It may be desirable to make these criteria adaptable to local policies or user decisions.</p> <p>Enumerated Values: PARTIAL = Partial content. COMPLETE = Complete content.</p>
Completion Flag Description	(0040,A492)	3	<p>Explanation of the value sent in Completion Flag (0040,A491).</p>
Verifying Observer Sequence	(0040,A073)	1C	<p>The person or persons authorized to verify documents of this type and accept responsibility for the content of this document. One or more Items may be included in this sequence.</p> <p>Required if Verification Flag (0040,A493) is VERIFIED.</p>
>Verifying Observer Name	(0040,A075)	1	<p>The person authorized by the Verifying Organization (0040,A027) to verify documents of this type and who accepts responsibility for the content of this document.</p>
>Verifying Observer Identification Code Sequence	(0040,A088)	2	<p>Coded identifier of Verifying Observer. Zero or one Items shall be permitted in this sequence.</p>
>>Include 'Code Sequence Macro' Table 8.8-1 (in DICOM Standard Part 3)			<p>No Baseline Context ID defined.</p>
>Verifying Organization	(0040,A027)	1	<p>Organization to which the Verifying Observer Name (0040,A075) is accountable in the current interpretation procedure.</p>
>Verification DateTime	(0040,A030)	1	<p>Date and Time of verification by the Verifying Observer Name (0040,A075).</p>
>Include 'SOP Instance Reference Macro' Table C.17-3 (in DICOM Standard Part3)			

Attribute Name	Tag	Type	Attribute Description
Current Requested Procedure Evidence Sequence	(0040,A375)	3	Full set of Composite SOP Instances, of which the creator is aware, which were created to satisfy the current Requested Procedure(s) for which this Document is generated or that are referenced in the content tree. One or more Items may be included in this sequence.
<i>>Include 'SOP Instance Reference Macro' Table C.17-3</i>			
Pertinent Other Evidence Sequence	(0040,A385)	3	Other Composite SOP Instances that are considered to be pertinent evidence by the creator of this Document. This evidence must have been acquired in order to satisfy Requested Procedures other than the one(s) for which this Document is generated. One or more Items may be included in this sequence.
Identical Documents Sequence	(0040,A525)	1C	Duplicates of this document, stored with different SOP Instance UIDs. One or more Items may be included in this sequence. Required if this document is stored with different SOP Instance UIDs in one or more other Studies.
<i>>Include 'SOP Instance Reference Macro' Table C.17-3 (in DICOM Standard Part 3)</i>			

4.7.5.1 Encapsulated Documents Attributes Extensions

1065 4.7.5.2 Concept Name Code Sequence

The Concept Name Code Sequence is the attribute used to provide standardized coded titles for documents. For this transaction, the Report Creator is required to be able to configure this attribute based upon the clinic requirements or a chosen industry standard.

1070 Note: This requirement allows users and implementations to identify the different types of encapsulated documents.

4.7.5.3 Source Instance Sequence

1075 The Source Instance Sequence is the attribute used to reference derived encapsulated documents. This attribute shall refer to SOP Instances (e.g. prior or provisional reports) whose content has been wholly or partially included in the encapsulated document. This amendment process of a document is not explicitly described, however, the use of this attribute allows tracking back to the previous version of this document.

4.7.5.4 PDF Version Requirements

1080 The DICOM standard does not define use of a specific version of PDF when encapsulated PDF is used. This may result in incorrect display of reports when using a different PDF version of software from that which was used to create the files. Common errors include blank or missing pages, missing or displaced graphics, or important changes in format, leading to risk for clinical error.

1085 Another difficulty is that PDF files are very large when only pixel data is used in the file. This causes unacceptable clinical impacts such as very slow network transmission speeds. Pixel data PDFs also may cause unreadable display upon zooming in or out, allowing only small portions of a document to be viewed at one time, etc. When searchable PDF is used to store information as text the files are much smaller, solving many of the issues identified. The ability to search the text files is an additional critical benefit, allowing a clinician to locate specific information quickly.

1090 ISO PDF based standards have been developed in order to address these issues. Report Creator Actors shall support PDF/A ISO 19005-1. Document management – Electronic document file format for long-term preservation- Part 1: Use of PDF (PDF/A).

1095 The PDF contents of the DICOM Encapsulated PDF objects shall conform to PDF/A-1a (level A conformance to the PDF/A Part 1 standard). This is intended to ensure that the rendered visual appearance of the document is reproducible across computer platforms and over the course of time, and that the document can be displayed in natural reading order on a mobile device (for example, a PDA) or other devices in accordance with Section 508 of the US Rehabilitation Act.

4.8 Query Displayable Report [EYECARE-8]

1100 This section corresponds to Transaction EYECARE-8 of the IHE Technical Framework. Transaction EYECARE-8 is used by the Report Reader and Report Repository actors.

4.8.1 Scope

In the Query Displayable Reports Transaction, the Report Reader queries the Report Repository for draft or final DICOM Encapsulated document.

1105 4.8.2 Use Case Roles

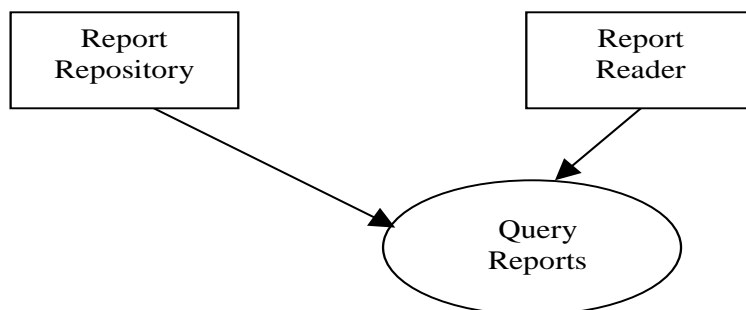

Actor: Report Repository

Role: Responds to queries for DICOM Encapsulated document.

Actor: Report Reader

1110 **Role:** Queries Report Repository for DICOM Encapsulated documents and makes them available for selection.

4.8.3 Referenced Standards

DICOM 2007 PS 3.4: Query/Retrieve Service Class

4.8.4 Interaction Diagram

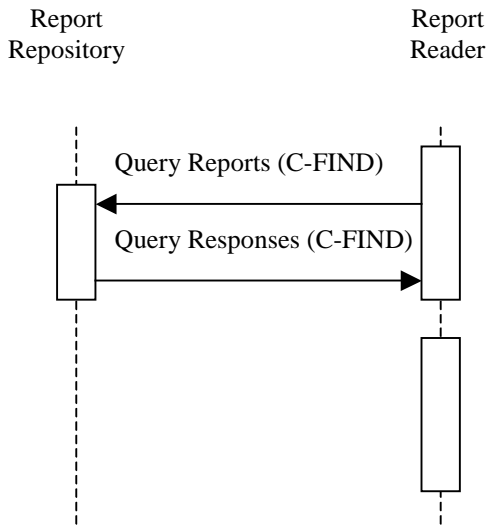

1115

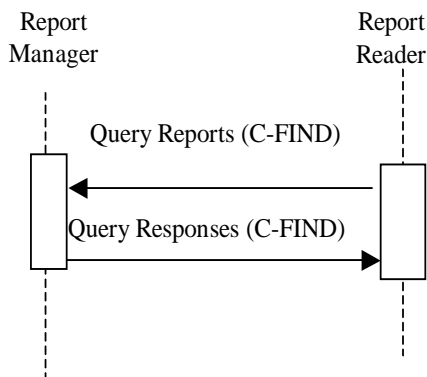

4.8.4.1 Query Displayable Reports

This transaction relates to the query section of the above interaction diagram. The Query (Study Root – FIND and optionally Patient Root – FIND) SOP Classes will be supported. Refer to DICOM 2007 PS 3.4: Query/Retrieve Service Class for detailed descriptive semantics.

1120

4.8.4.1.1 Trigger Events

The user at the Report Reader wishes to view selected reports.

4.8.4.1.2 Message Semantics

The message semantics are defined by the DICOM Query/Retrieve SOP Classes.

- 1125 A C-FIND Request from the DICOM Study Root Query/Retrieve Information Model – FIND SOP Class or the DICOM Patient Root Query/Retrieve Information Model – FIND SOP Class shall be sent from the Report Reader to the Report Repository.

The Report Reader uses one or more matching keys as search criteria to obtain the list of matching entries in the Report Repository at the selected level (Patient & Study/Series/Instance).

- 1130 In addition to the required and unique keys defined by the DICOM Standard, the IHE Technical Framework has defined matching and return keys to be supported by query SCUs and SCPs. The keys are defined in [RAD-14] (see RAD TF-2: 4.14), except that Report Reader and Report Repositories are not required to support PPS Start Date and PPS Start Time. The conventions for key usage are defined in section 2.2. For the Report Reader (SCU) and the Report Repository (SCP) the additional document Instance specific keys are defined in table 4.8-1.
- 1135

1140 **Table 4.8-1. Document Instance Specific Query Matching and Return Keys**

Attribute Name	Tag	Query Keys Matching		Query Keys Return	
		SCU	SCP	SCU	SCP
Instance Specific Level					
Document Title	(0042,0010)	O	O	R+	R+
Completion Flag	(0040,A491)	R+	R+	R+	R+
Verification Flag	(0040,A493)	R+	R+	R+	R+
Content Date	(0008,0023)	O	O	R+	R+
Content Time	(0008,0033)	O	O	R+	R+
Verifying Observer Sequence	(0040,A073)				
>Verifying Organization	(0040,A027)	O	O	R+	R+
>Verification DateTime	(0040,A030)	R+	R+	R+	R+
>Verifying Observer Name	(0040,A075)	R+	R+	R+	R+
>Verifying Observer Identification Code Sequence	(0040,A088)				
>> Code Value	(0008,0100)	O	O	O	R+
>> Coding Scheme Designator	(0008,0102)	O	O	O	R+
>> Coding Scheme Version	(0008,0103)	O	O	O	R+
>> Code Meaning	(0008,0104)	O	O	O	R+
Concept Name Code Sequence	(0040,A043)				
>Code Value	(0008,0100)	R+	R+	R+	R+
>Coding Scheme Designator	(0008,0102)	R+	R+	R+	R+
>Coding Scheme Version	(0008,0103)	O	O	O	R+

>Code Meaning	(0008,0104)	O	O	R+	R+
---------------	-------------	---	---	----	----

4.8.4.1.3 Expected Actions

The Report Repository receives the C-FIND request, performs the matching on the provided keys and sends the list of matching records back to the Report Reader via C-FIND responses.

4.9 Retrieve Displayable Reports [EYECARE-9]

1145 This section corresponds to Transaction EYECARE-9 of the IHE Technical Framework. Transaction EYECARE-9 is used by the Report Reader and Report Repository actors.

4.9.1 Scope

In the Retrieve Displayable Reports Transaction, the requested DICOM Encapsulated documents are transferred from the Report Repository to the Report Reader for viewing.

1150 4.9.2 Use Case Roles

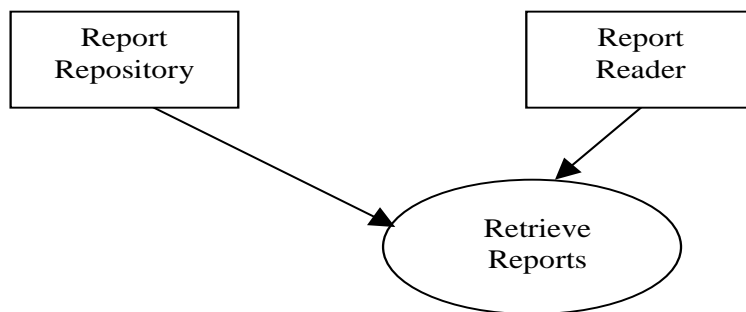

Actor: Report Repository

Role: Sends requested DICOM Encapsulated document to Report Reader.

1155 **Actor:** Report Reader

Role: Retrieves DICOM Encapsulated document from Report Repository and makes them available for viewing.

4.9.3 Referenced Standards

DICOM 2007 PS 3.4: Query/Retrieve Service Class

1160 DICOM 2007 PS 3.4: Storage SOP Class

4.9.4 Interaction Diagram

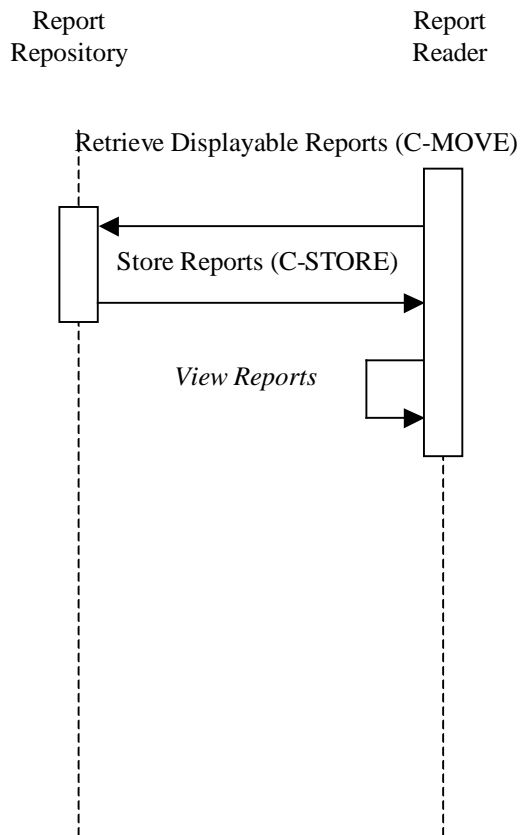

1165 4.9.4.1 Retrieve Reports

This transaction relates to the retrieve section of the above interaction diagram. The Retrieve (Study Root – MOVE and optionally Patient Root – MOVE) SOP Classes shall be supported. The Report Reader as an SCP shall support the DICOM Encapsulated Document Storage SOP Class. The Report Repository as an SCU shall support DICOM Encapsulated Document Storage SOP Class. Refer to DICOM PS 3.4, Annex C, for detailed descriptive semantics.

1170

4.9.4.1.1 Trigger Events

The user at the Report Reader selects specific reports to view.

4.9.4.1.2 Message Semantics

The DICOM Query/Retrieve SOP Classes and the DICOM Encapsulated Storage SOP Classes define the message semantics.

1175

A C-MOVE Request from the DICOM Study Root Query/Retrieve Information Model – MOVE SOP Class or the DICOM Patient Root Query/Retrieve Information Model – MOVE SOP Class shall be sent from the Report Reader to the Report Repository.

4.9.4.1.3 Expected Actions

1180 The Report Repository receives the C-MOVE request, establishes a DICOM association with the Report Reader and uses the appropriate DICOM Encapsulated Document Storage SOP Classes to transfer the requested reports.

Report Repository responds to the queries with the information from the DICOM instances it received from the Report Creator.

1185 The Report Repository and Report Reader shall support the SOP Class (es) defined in table 4.7.5-1.

4.9.4.2 View Reports

This transaction relates to the “View Reports” event of the above interaction diagram.

4.9.4.3 Trigger Events

1190 The Report Reader receives reports from the Report Repository.

4.9.4.4 Invocation Semantics

This is a local invocation of functions at the Report Reader, and the method used by the Report Reader to interpret and display the report data in a meaningful way is outside the scope of the IHE Technical Framework.

1195 4.9.4.5 Expected Actions

The Report Reader presents to the user a DICOM Encapsulated document.

4.9.4.6 PDF Version Requirements

1200 The DICOM standard does not define use of a specific version of PDF when encapsulated PDF is used. This may result in incorrect display of reports when using a different PDF version of software from that which was used to create the files. Common errors include blank or missing pages, missing or displaced graphics, or important changes in format, leading to risk for clinical error.

1205 ISO PDF based standards have been developed in order to address these issues. Report Reader Actors shall support PDF/A ISO 19005-1. Document management – Electronic document file format for long-term preservation- Part 1: Use of PDF (PDF/A).

The Report Display Actor shall conform to the PDF/A reader requirements for the display of DICOM Encapsulated PDF documents that are conformant to the PDF/A standard. This is intended to ensure the correct visual rendering of these documents.

1210

4.10 Instructions for Performing a Procedure- Placer Order Management [EYECARE-10]

1215 This transaction is based upon Placer Order Management [RAD-2] (see RAD TF: 2 4.2), with the extension to transmit health care provider instructions to the technician prior to performing a procedure.

4.10.1 Scope

1220 This transaction is used by the Order Placer to place a new order to the DSS/Order Filler Actor (it also supports the ability to cancel an order). During the creation of a new order, a health care provider may wish to include instructions to the technician. For example there might be instructions to tape the eyelids while performing a visual field or to concentrate on a specific region of the eye during the early stage of an angiogram, etc.

4.10.2 Use Case Roles

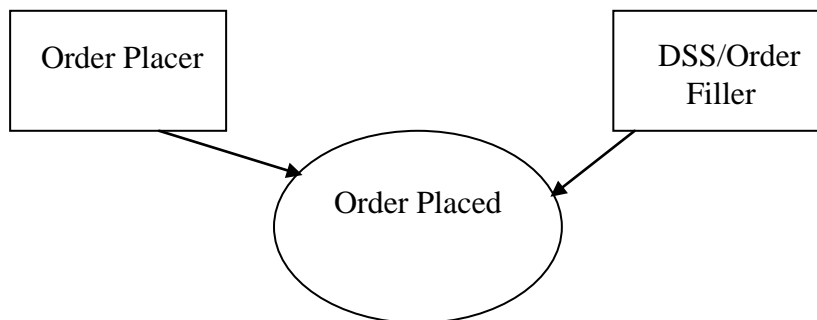

1225

Actor: Order Placer

Role: Places orders. Cancels orders as necessary.

Actor: DSS/OF

Role: Receives and processes (fills) orders. Receives order cancelations.

1230 4.10.3 Referenced Standards

HL7 2.3.1 Chapter 4

4.10.4 Interaction Diagrams

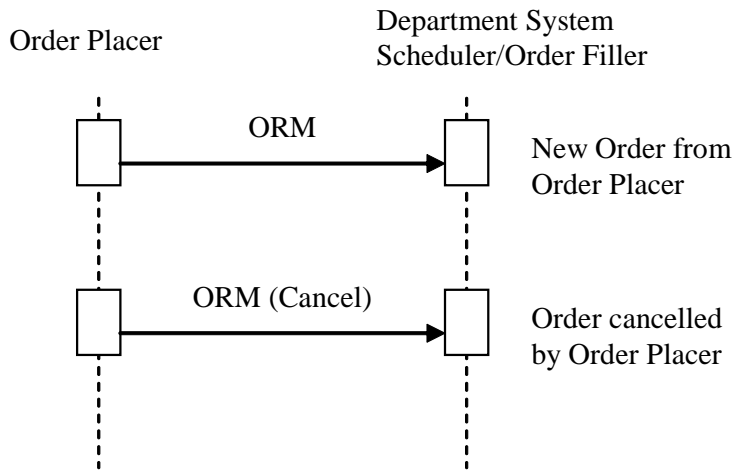

1235 **4.10.4.1.1 Order Management – New Order from Order Placer**

4.10.4.1.2 Trigger Events

ORM – The Order Placer places a new order for the DSS/Order Filler that may contain specific procedure instructions to the technician performing the procedure.

4.10.4.1.3 Message Semantics

1240 When an order is created, the Order Placer provides a mechanism for the health care provider to enter free text instructions to the technician who will be performing the procedure. The Order Placer transmits these instructions using the NTE segment of the ORM HL7 message to the DSS/OF (i.e., the NTE segment becomes mandatory when instructions are provided).

1245 The message semantics are as defined in [RAD-2] (see RAD TF-2 4.2) with the extension for supporting the HL7 NTE segment to provide textual instructions.

For this [EYECARE-10] extension, the table in RAD TF-2: 4.2.4.1.2 shall be extended as defined by Table 4.10.4.1.2-1 below.

Table 4.10.4.1.2-1 – HL7 ORM Message

ORM	General Order Message	Chapter in HL7 v2.3.1
NTE	Notes and Comments (for Detail)	2 Required if instructions are provided. It may be present otherwise.

1250

4.10.4.1.3.1 NTE - Notes and Comments Segment

The NTE segment is a common format for sending notes and comments. The element Source of Comment shall contain “LPI” to denote that the instruction is a Limited Procedure Instruction.

1255 Although the NTE Comment Element allows for 64K, the length shall be limited to 10,240 characters to accommodate the DICOM Modality Worklist Requested Procedure Comments attribute length to which this value maps (see Procedure Instructions Option in [EYECARE-1]).

Note: DICOM, HL7 and IHE length limit is characters, but many implementations make the mistake of using bytes. For example the UTF-8 encodings of characters are frequently multiple bytes; therefore if UTF-8 was used the actual length in bytes could be as much as 20,480 bytes.

1260

Table 4.10.4.1.2.1-1 NTE attributes

SEQ	LEN	DT	OPT	RP/#	TBL#	ITEM #	ELEMENT NAME
1	4	SI	O			00096	Set ID - NTE
2	8	ID	R2		0105	00097	Source of Comment
3	10,240	FT	R2	Y		00098	Comment
4	60	CE	O			01318	Comment Type

Modified Table 0105 Source of comment

Table	Code	Code Meaning
0105	LPI	Limited Procedure Instruction

4.10.4.1.4 Expected Actions

1265 The expected actions are defined in RAD TF- 2: 4.2, with the following extension.

The Order Placer Actor shall provide a mechanism to convey procedure instructions and if provided, these instructions shall be included in the ORM Message, within the NTE segment directly following each relative procedure detail (OBR) segment. The DSS/OF shall be able to process the NTE segment for use in further transactions.

1270

Note: The DSS/Order Filler uses the Procedure Instructions Option in [EYECARE-1] to convey the instructions to the Acquisition Modality or Acquisition Modality Importer actor using DICOM Modality Worklist.

1275 4.11 Instructions for Performing a Procedure- Filler Order Management [EYECARE-11]

This transaction is based upon Filler Order Management [RAD-3] (see RAD TF-2 4.3), with the extension to transmit health care provider instructions to the technician prior to performing a procedure.

1280 **4.11.1 Scope**

This transaction is used by the Order Filler to inform the Order Placer about the orders it creates and cancels, including the status of the orders it is fulfilling. If the Order Filler needs to change an order, it has to do so as a combination of Order Cancel followed by New Order.

1285 During the creation of a new order, a health care provider may wish to include instructions to the technician. For example, there might be instructions to tape the eyelids while performing a visual field or to concentrate on a specific region of the eye during the early stage of an angiogram, etc.

4.11.2 Use Case Roles

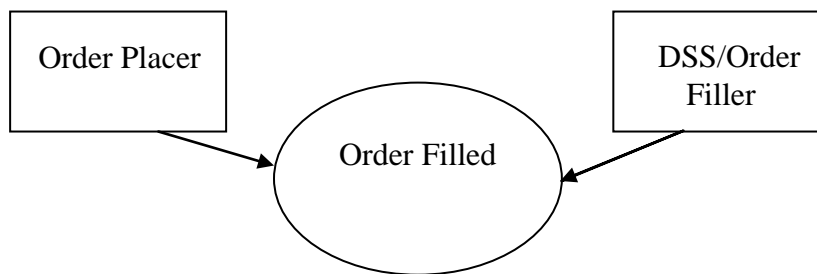

1290

Actor: Order Placer

Role: Receives new order and order cancellation requests from Order Filler. Receives Order Status updates from Order Filler.

Actor: Department System Scheduler/Order Filler

1295 **Role:** Creates new or cancels existing orders; sends notifications of order status to the Order Placer.

4.11.3 Referenced Standards

HL7 2.3.1 Chapters 4

4.11.4 Interaction Diagrams

1300

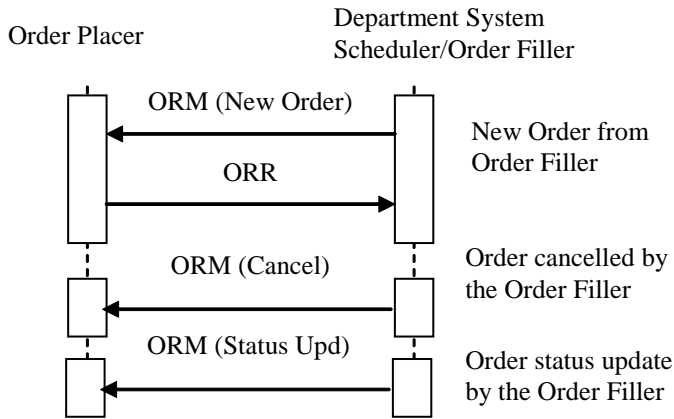

4.11.4.1.1 Filler Order Management – New Order from Order Filler

4.11.4.1.2 Trigger Events

1305 ORM - Department System Scheduler/Order Filler places an order that may contain specific procedure instructions to the technician performing the procedure.

4.11.4.1.3 Message Semantics

1310 When an order is created, the DSS/Order Filler provides a mechanism for the health care provider to enter free text instructions to the technician who will be performing the procedure. The DSS/Order Filler transmits these instructions using the NTE segment of the ORM HL7 message to the Order Placer (i.e., the NTE segment becomes mandatory when instructions are provided).

The message semantics are as defined in [RAD-3] (see RAD TF-2 4.3) with the extension for supporting the HL7 NTE segment to provide textual instructions.

1315 For this [EYECARE-11] extension, the table in RAD TF-2: 4.3.4.1.2 shall be extended as defined by Table 4.11.4.1.2-1 below.

Table 4.11.4.1.2-1 – HL7 ORM Message

ORM	General Order Message	Chapter in HL7 v2.3.1
NTE	Notes and Comments (for Detail)	2 Required if instructions are provided. It may be present otherwise.

1320

4.11.4.1.3.1 NTE - Notes and Comments Segment

The NTE segment is a common format for sending notes and comments. The element Source of Comment shall contain “LPI” to denote that the instruction is a Limited Procedure Instruction.

1325

Although the NTE Comment Element allows for 64K, the length shall be limited to 10,240 characters to accommodate the DICOM Modality Worklist Requested Procedure Comments attribute length to which this value maps (see Procedure Instructions Option in [EYECARE-1]).

Table 4.11.4.1.2.1-1 NTE attributes

SEQ	LEN	DT	OPT	RP/#	TBL#	ITEM #	ELEMENT NAME
1	4	SI	O			00096	Set ID - NTE
2	8	ID	R2		0105	00097	Source of Comment
3	10,240	FT	R2	Y		00098	Comment
4	60	CE	O			01318	Comment Type

Modified Table 0105 Source of comment

Table	Code	Code Meaning
0105	LPI	Limited Procedure Instruction

1330

4.11.4.1.4 Expected Actions

The expected actions are defined in RAD TF-2: 4.3, with the following extension.

1335

The DSS/Order Filler Actor shall provide a mechanism to convey procedure instructions and if provided, these instructions shall be included in the ORM Message, within the NTE segment directly following each relative procedure detail (OBR) segment. The Order Placer shall be able to process the NTE segment.

1340

Note: The DSS/Order Filler uses the Procedure Instructions Option in [EYECARE-1] to convey the instructions to the Acquisition Modality or Acquisition Modality Importer actor using DICOM Modality Worklist. The Acquisition Modality or Acquisition Modality Importer actor will then display the instruction to the technician.